



Αθόρυβες Οριζόντιες
Πολυβάθμιες Αντλίες

Horizontal Multistage
Booster Pumps



Χαρακτηριστικά

- Οριζόντιες μη αυτόματης αναρρόφησης αθόρυβες πολυβάθμιες φυγοκεντρικές αντλίες, συνδεδεμένες με ηλεκτρικό κινητήρα
- Οι πτερωτές και οι θάλαμοι είναι από ανοξείδωτο χάλυβα, για να επιτευχθεί μεγαλύτερη διάρκεια ζωής, υψηλή απόδοση και αξιοπιστία
- Μεγάλο εύρος λειτουργίας
- Διαθέσιμο για κατασκευή από ανοξείδωτο χάλυβα AISI304 και AISI316

Απόδοση

- Παροχή μέχρι 32 m³/h.
- Μανομετρικό μέχρι 90 m.
- Ισχύς ηλεκτροκινητήρα από 0,55 kW μέχρι 7,5 kW.
- Κινητήρες κλειστού τύπου, αερόψυκτοι, διπολικοί
- Κλάση μόνωσης F, προστασία IP 55
- Ταχύτητα περιστροφής 3500 r.p.m. (60 Hz).

Εφαρμογές

- Συστήματα κλιματισμού
- Συστήματα ψύξης
- Βιομηχανικού καθαρισμού
- Ιχθυοκαλλιέργειες
- Συστήματα λιπάσματος
- Πιεστικά συγκροτήματα

Features

- Horizontal non-self priming multistage centrifugal pump, attached with shaft electric motor
- Impellers and diffusers made of stainless steel in order to achieve durability, superior efficiency and the highest performances
- Wide range
- Available in stainless steel AISI304 or AISI316

Performance

- Capacity up to 32 m³/h.
- Head up to 90 m.
- Rated motor power output 0,55 kW up to 7,5 kW.
- TEFC, 2-pole standard motor
- Class F insulation, IP 55 protection
- Rotation speed 3500 r.p.m. (60 Hz).

Applications

- Air condition system
- Cooling system
- Industrial cleaning
- Aquiculture
- fertilizing system

SH, SHI, SHN Εύρος Λειτουργίας σε 60Hz

SH, SHI, SHN Performance range at 60Hz

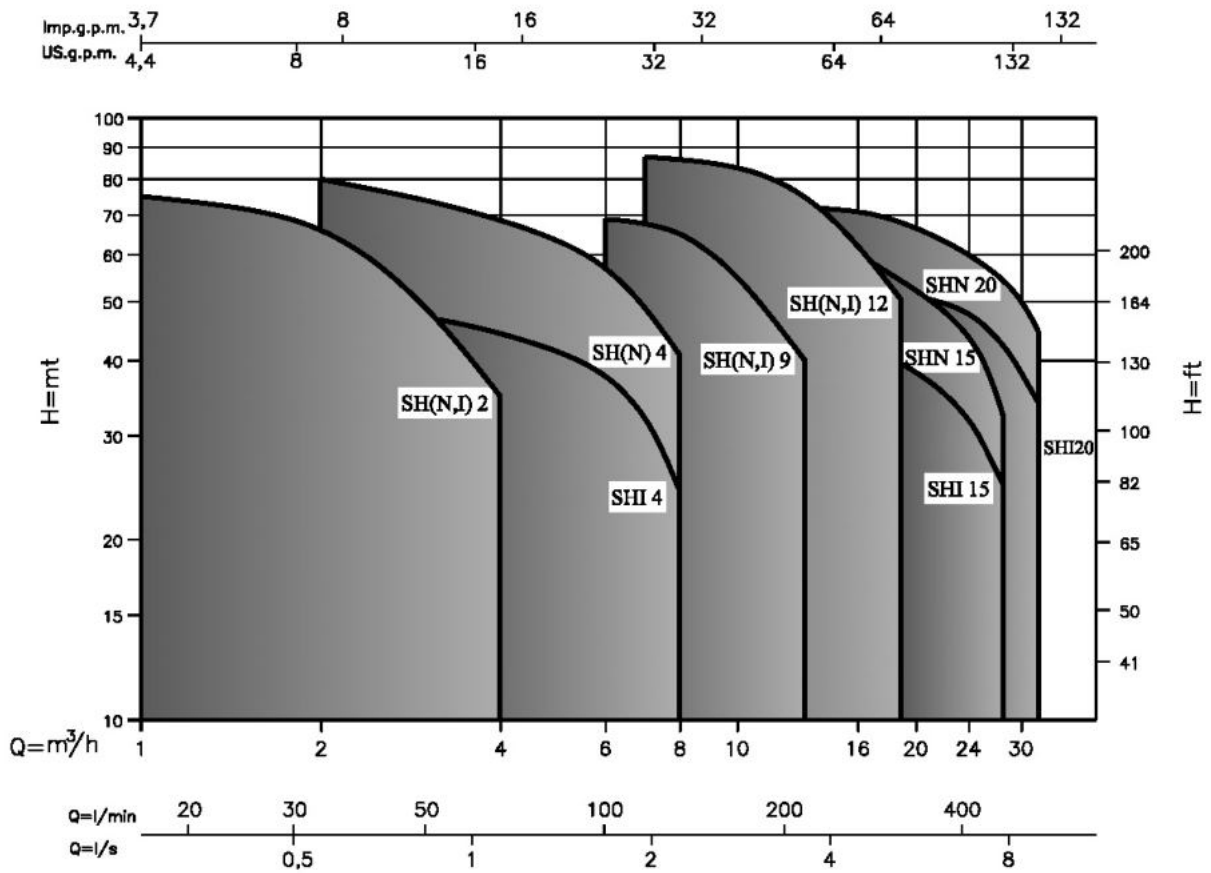

Τομή SHI 2,4

Section view SHI 2, 4

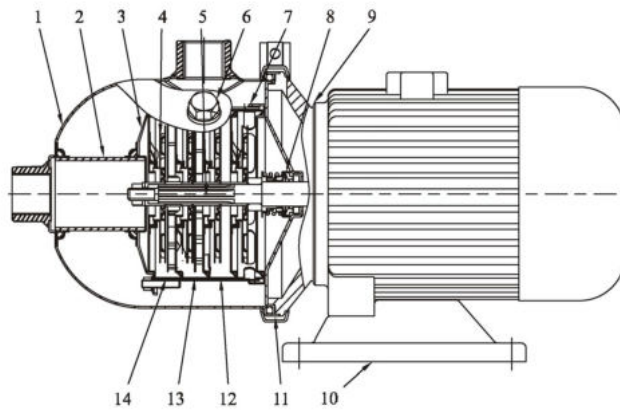

Τομή SHI 9,12,15,20

Section view SHI 9, 12, 15, 20

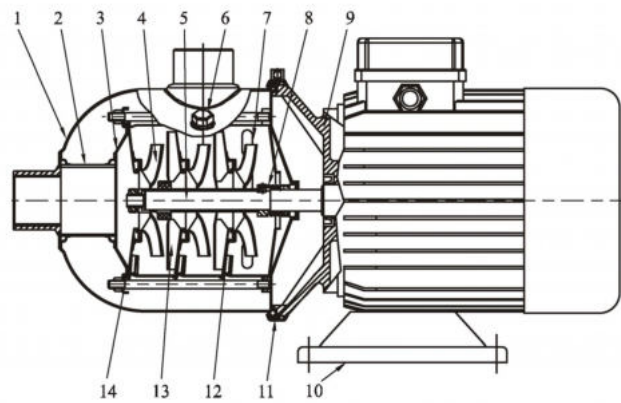

Τομή SH, SHN 2, 4, 9, 12, 15, 20

Section view SH, SHN

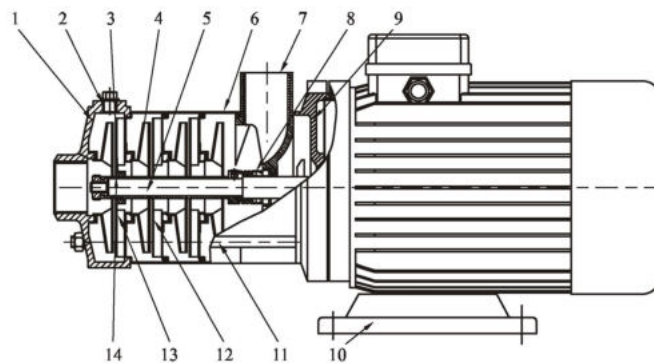

SHI

N.	Περιγραφή Description	Υλικά Material	AISI/ASTM
1	Εισαγωγή και εξαγωγή Inlet and outlet chaber	Ανοξείδωτος Χαλυβας Stainless steel	AISB 16
2	Σωλήνα σύνδεσης Connection Pipe	Ανοξείδωτος Χαλυβας Stainless steel	AISB 16
3	Δίσκος Σύσφιξης Clamp Plate	Ανοξείδωτος Χαλυβας Stainless steel	AISB 16
4	Πτερωτή Impeller	Ανοξείδωτος Χαλυβας Stainless steel	AISB 16
5	Άξονας Shaft	Ανοξείδωτος Χαλυβας Stainless steel	AISB 16
6	Τάπα Gag	Ανοξείδωτος Χαλυβας Stainless steel	AISB 16
7	Κατάθλιψη Discharge diffuser	Ανοξείδωτος Χαλυβας Stainless steel	AISB 16
8	Μηχανικός στυπιοθλίπτης Mechanical seal		
9	Μανδύας κινητήρα Motor end cover	Αλουμίνιο Aluminium alloy	
10	Βάση στήριξης Base plate	Χυτοσίδηρος Cast iron	AS TM25B
11	Οπή έλξης Pull-rod	Ανοξείδωτος Χαλυβας Stainless steel	AISB 16
12	Βαθμίδα Diffuser	Ανοξείδωτος Χαλυβας Stainless steel	AISB 16
13	Στήριγμα βαθμίδας Support diffuser	Ανοξείδωτος Χαλυβας Stainless steel	AISB 16
14	Επαγωγέας Inducer	Ανοξείδωτος Χαλυβας Stainless steel	AISB 16

SH, SHN

N.	Περιγραφή Description	Υλικά Material	AISI/ASTM
2	Τάπα Gag	Ανοξείδωτος Χαλυβας Stainless steel	AISI304
3	Έδρανο Bearing	Καρβίδιο βολφραμίου Tungsten carbide	
4	Πτερωτή Impeller	Ανοξείδωτος Χαλυβας Stainless steel	AISI304
5	Άξονας Shaft	Ανοξείδωτος Χαλυβας Stainless steel	AISI304
6	Κατάθλιψη Discharge diffuser	Ανοξείδωτος Χαλυβας Stainless steel	AISI304
8	Μηχανικός στυποθλιπτης Mechanical seal		
9	Μανδύας κινητήρα Motor end cover	Αλουμίνιο Aluminium alloy	
10	Βάση στήριξης Base plate	Χυτοσίδηρος Cast iron	ASTM25B
11	Οπή έλξης Pull-rod	Ανοξείδωτος Χαλυβας Stainless steel	AISI304
12	Βαθμίδα Diffuser	Ανοξείδωτος Χαλυβας Stainless steel	AISI304
13	Στήριγμα βαθμίδας Support diffuser	Ανοξείδωτος Χαλυβας Stainless steel	AISI304
14	Μανδύας Πτερωτής Impeller sleeve	Ανοξείδωτος Χαλυβας Stainless steel	AISI304
SHN			
1	Αναρρόφηση Suction head	Ανοξείδωτος Χαλυβας Stainless steel	AISI304
7	Κατάθλιψη Discharge head	Ανοξείδωτος Χαλυβας Stainless steel	AISI304
SH			
1	Αναρρόφηση Suction head	Χυτοσίδηρος Cast iron	ASTM25B
7	Κατάθλιψη Discharge head	Χυτοσίδηρος Cast iron	ASTM25B

Αποδόσεις σε / Performance at 3500 r.p.m. 60 Hz

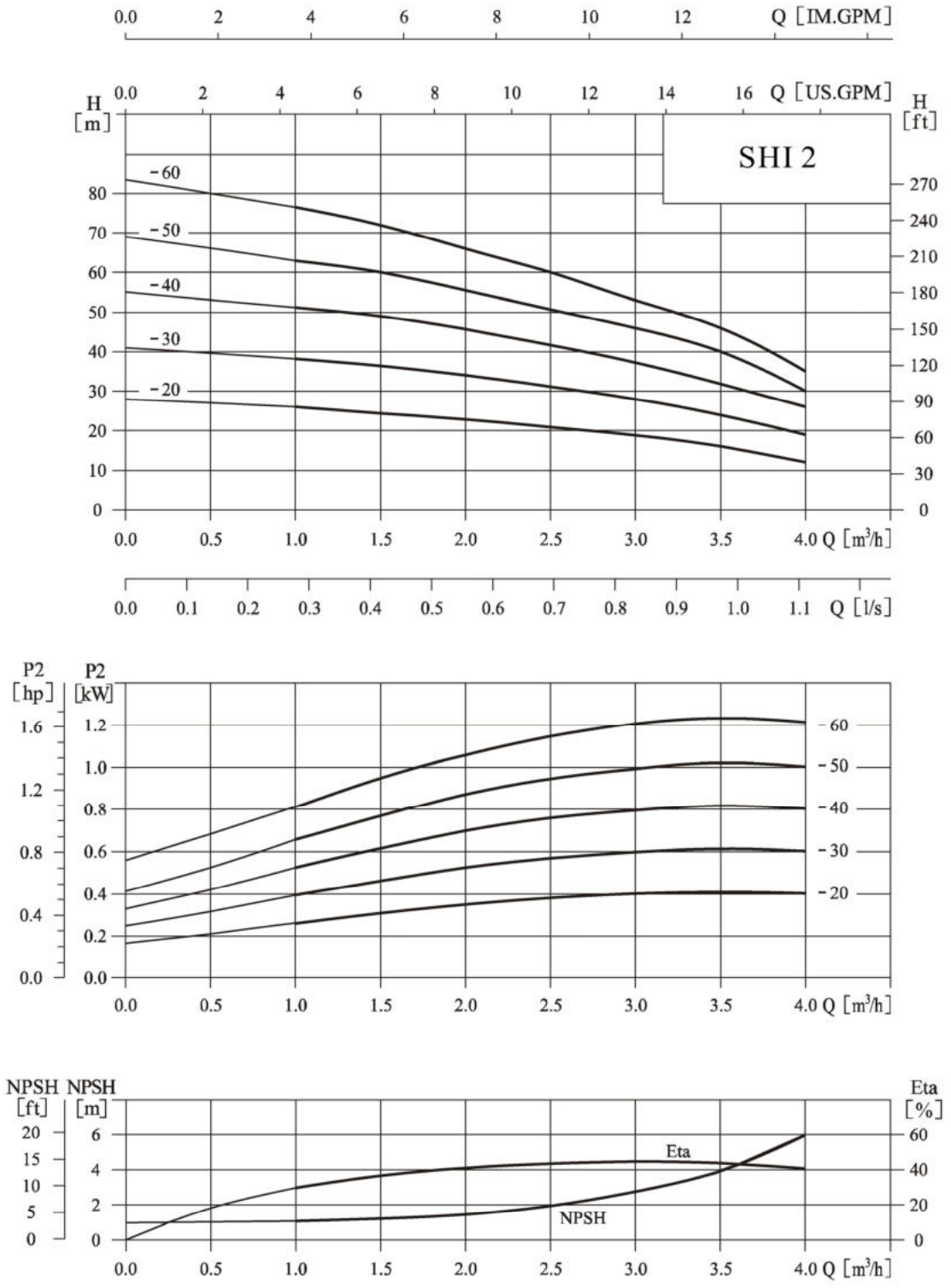

Αποδόσεις / Performance table

Τύπος Type	Ισχύς (KW)	Q (m ³ /h)	0,5	1	1,5	2	2,5	3	3,5	4
SHI 2-20	0,55	H (m)	27	26	24	23	21	19	16	12
SHI 2-30	0,75		40	38	36	34	31	28	24	19
SHI 2-40	1,1		53	51	49	46	41	37	32	26
SHI 2-50	1,1		66	63	60	56	51	46	40	30
SHI 2-60	1,5		80	76	72	66	60	53	46	35

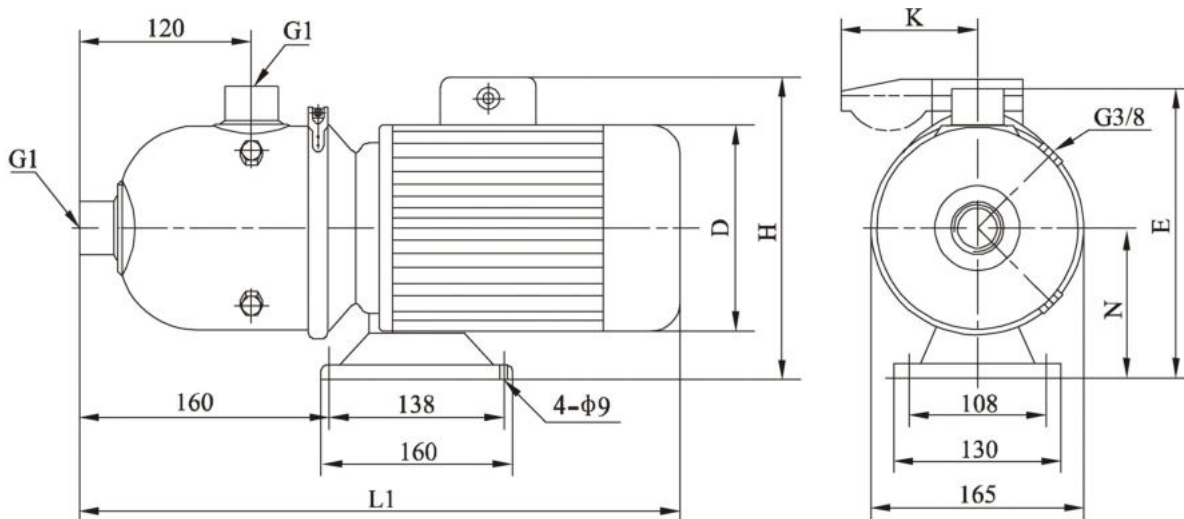

Διαστάσεις και Βάρη / Dimension and Weight

Κινητήρας Motor	Τύπος Type	Μήκος/Length (mm)						Βάρος Weight (kg)
		L1	H	N	D	E	K	
Three Phase/ Single phase	SHI 2-20	400	215/230	110	145	210	/96	13
	SHI 2-30	420	220/245	110	160	210	/100	13
	SHI 2-40	420	230/245	110	170	210	/100	15
	SHI 2-50	420	230/245	110	170	210	/100	15
	SHI 2-60	470	240/260	118	170	218	/100	20

Αποδόσεις σε / Performance at 3500 r.p.m. 60 Hz

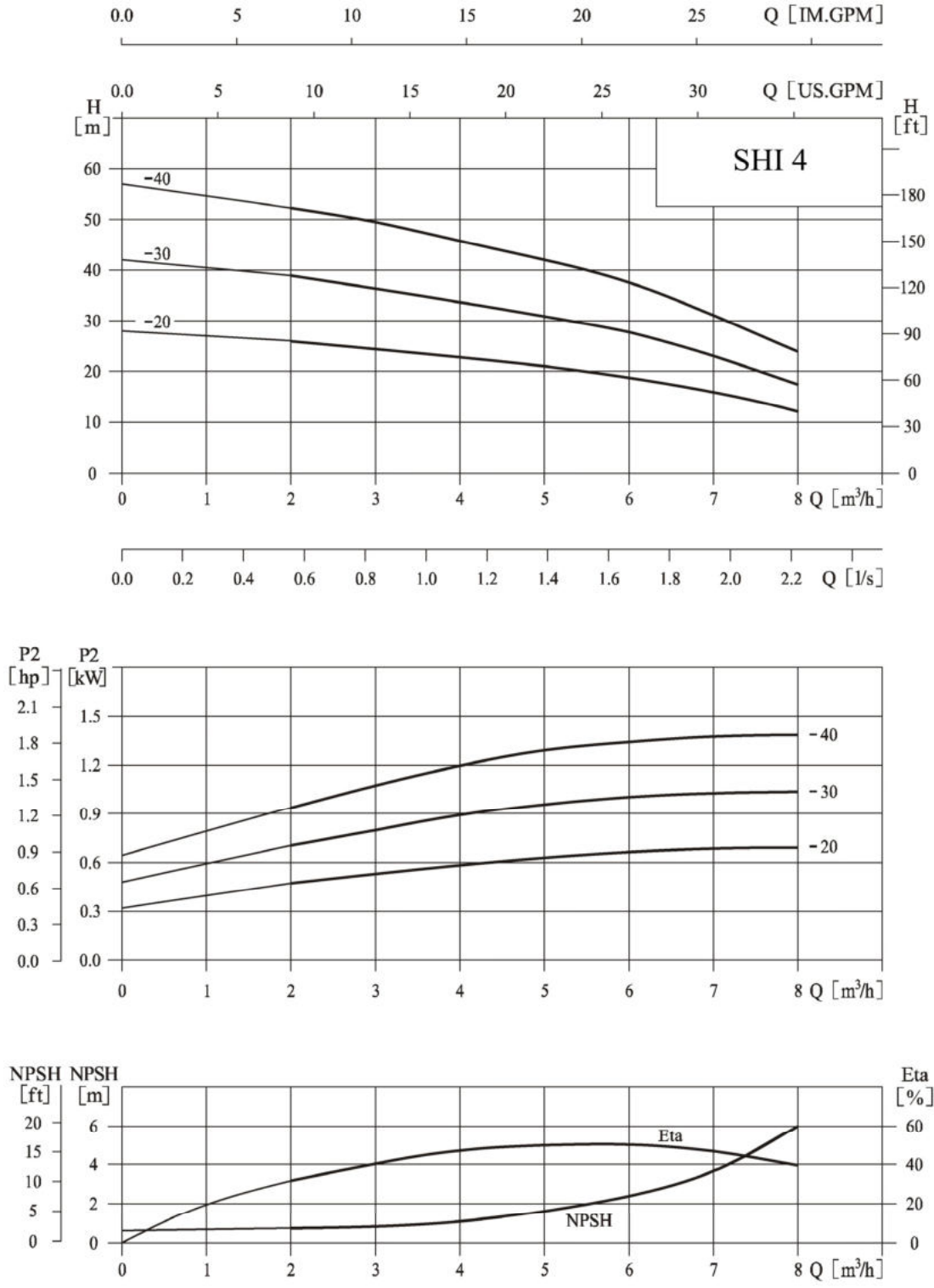

Αποδόσεις / Performance table

Τύπος Type	Ισχύς (KW)	Q (m ³ /h)	0,5	2	3	4	5	6	7	8
SHI 4-20	0,75	H (m)	28	26	24	23	21	19	16	12
SHI 4-30	1,1		42	39	36	34	31	28	24	18
SHI 4-40	1,5		56	53	49	46	42	38	31	24

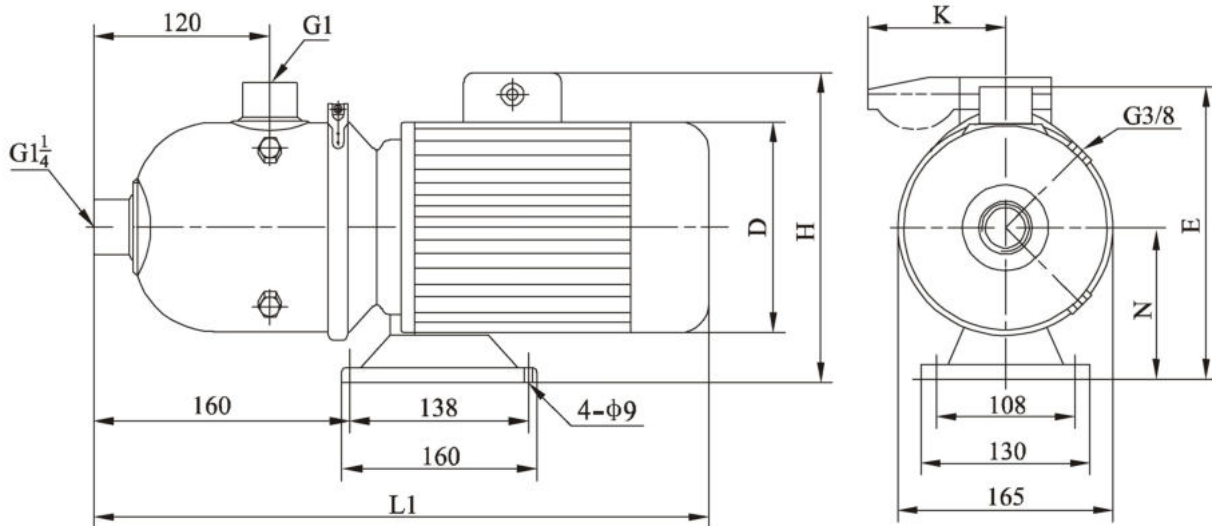

Διαστάσεις και Βάρη / Dimension and Weight

Κινητήρας Motor	Τύπος Type	Μήκος/Length (mm)						Βάρος Weight (kg)
		L1	H	N	D	E	K	
Three Phase/ Single phase	SHI 4-20	420	230/245	110	160	210	/100	12
	SHI 4-30	420	230/245	110	170	210	/100	15
	SHI 4-40	470	240/260	118	170	228	/100	20

Αποδόσεις σε / Performance at 3500 r.p.m. 60 Hz

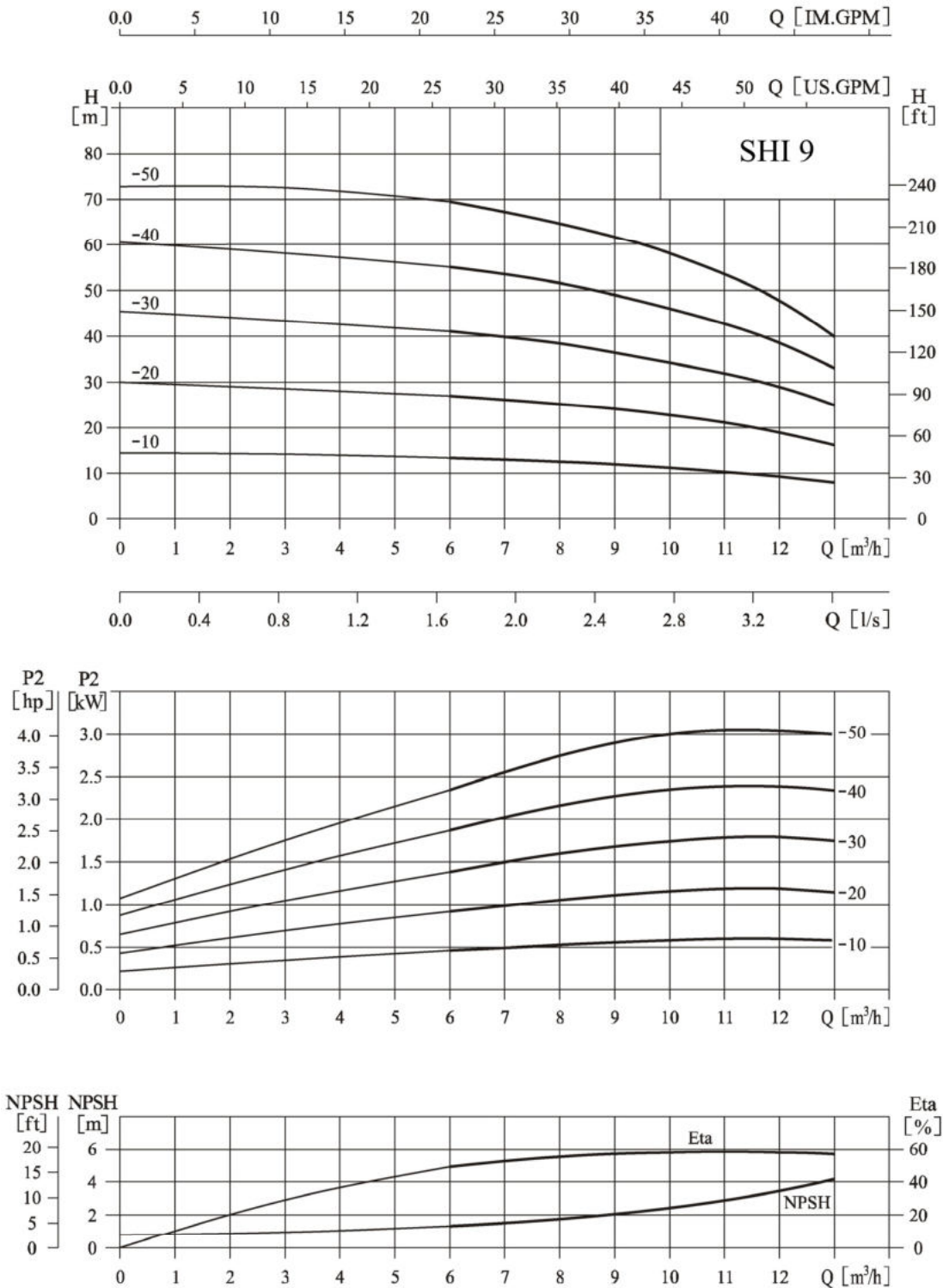

Αποδόσεις / Performance table

Τύπος Type	Ισχύς (KW)	Q (m ³ /h)	0,5	6	8	9	10	11	12	13
SHI 9-10	0,75	H (m)	14	13	12	11,5	11	10	9	8
SHI 9-20	1,5		30	27	25	24	23	21	19	16
SHI 9-30	2,2		44	41	39	37	34	32	29	25
SHI 9-40	3		60	55	52	49	46	43	39	33
SHI 9-50	3		73	69	65	62	58	54	48	40

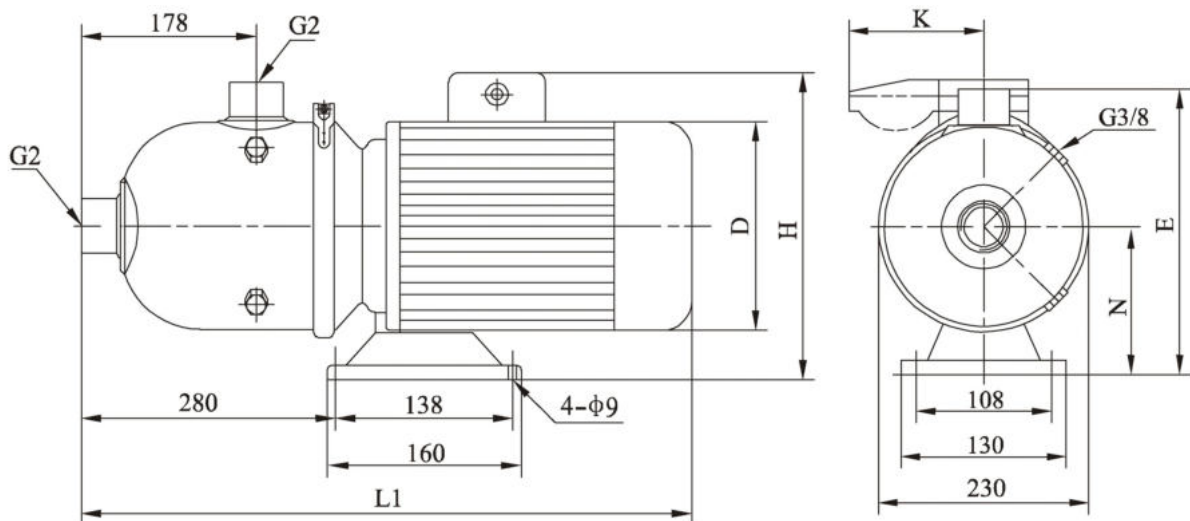

Διαστάσεις και Βάρη / Dimension and Weight

Κινητήρας Motor	Τύπος Type	Μήκος/Length (mm)						Βάρος Weight (kg)
		L1	H	N	D	E	K	
Three Phase/ Single phase	SHI 9-10	560	230/265	117	160	263	/100	20
	SHI 9-20	580	230/270	118	170	264	/100	25
	SHI 9-30	580	230/270	118	180	264	/100	25
	SHI 9-40	610	270/-	128	195	274	-	30
	SHI 9-50	610	270/-	128	195	274	-	30

Αποδόσεις σε / Performance at 3500 r.p.m. 60 Hz

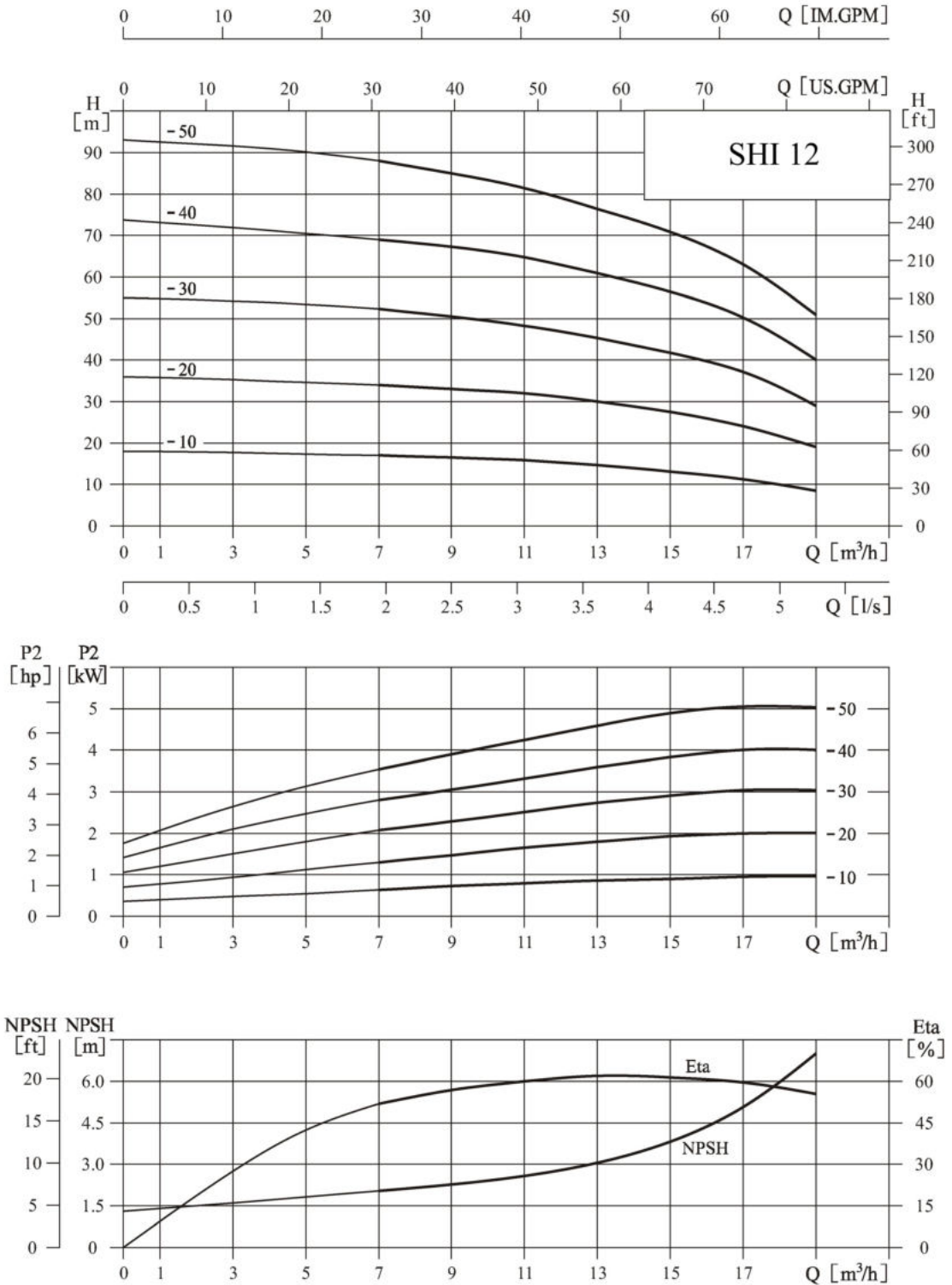

Αποδόσεις / Performance table

Τύπος Type	Ισχύς (KW)	Q (m ³ /h)	0,5	7	9	11	12	13	15	17	19
SHI 12-10	1,1	H (m)	18	17	16,5	16	15	14,5	13	11,5	9
SHI 12-20	2,2		36	34	33	32	31	30	27	25	19
SHI 12-30	3		55	52	50	49	47	45	42	38	29
SHI 12-40	4		73	69	68	65	63	61	56	50	40
SHI 12-50	5,5		92	88	85	82	79	76	71	63	51

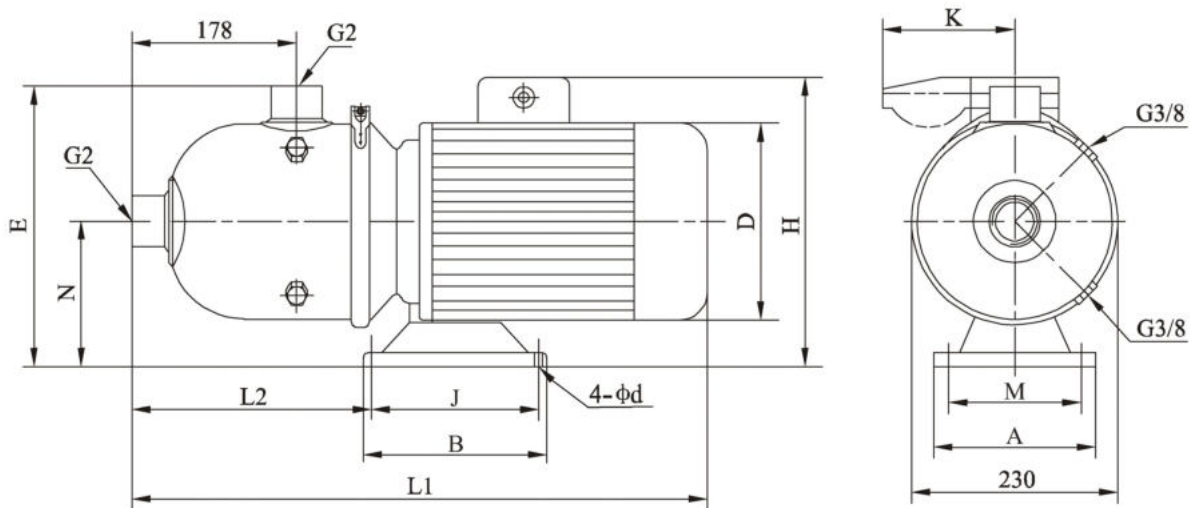

Διαστάσεις και Βάρη / Dimension and Weight

Κινητήρας Motor	Τύπος Type	Μήκος/Length (mm)											Βάρος Weight (kg)	
		L1	L2	H	D	E	N	A	M	B	J	d		K
Three Phase/ Single phase	SHI 12-10	560	280	230/265	180	268	118	130	108	160	138	9	/100	22
	SHI 12-20	580	280	240/270	180	268	118	130	108	160	138	9	/100	25
	SHI 12-30	610	270	270/-	195	276	126	130	108	160	138	9	-	32
	SHI 12-40	650	360	270/-	220	270	120	230	190	170	140	12	-	44
	SHI 12-50	670	375	305/-	255	282	132	260	216	190	140	12	-	58

Αποδόσεις σε / Performance at 3500 r.p.m. 60 Hz

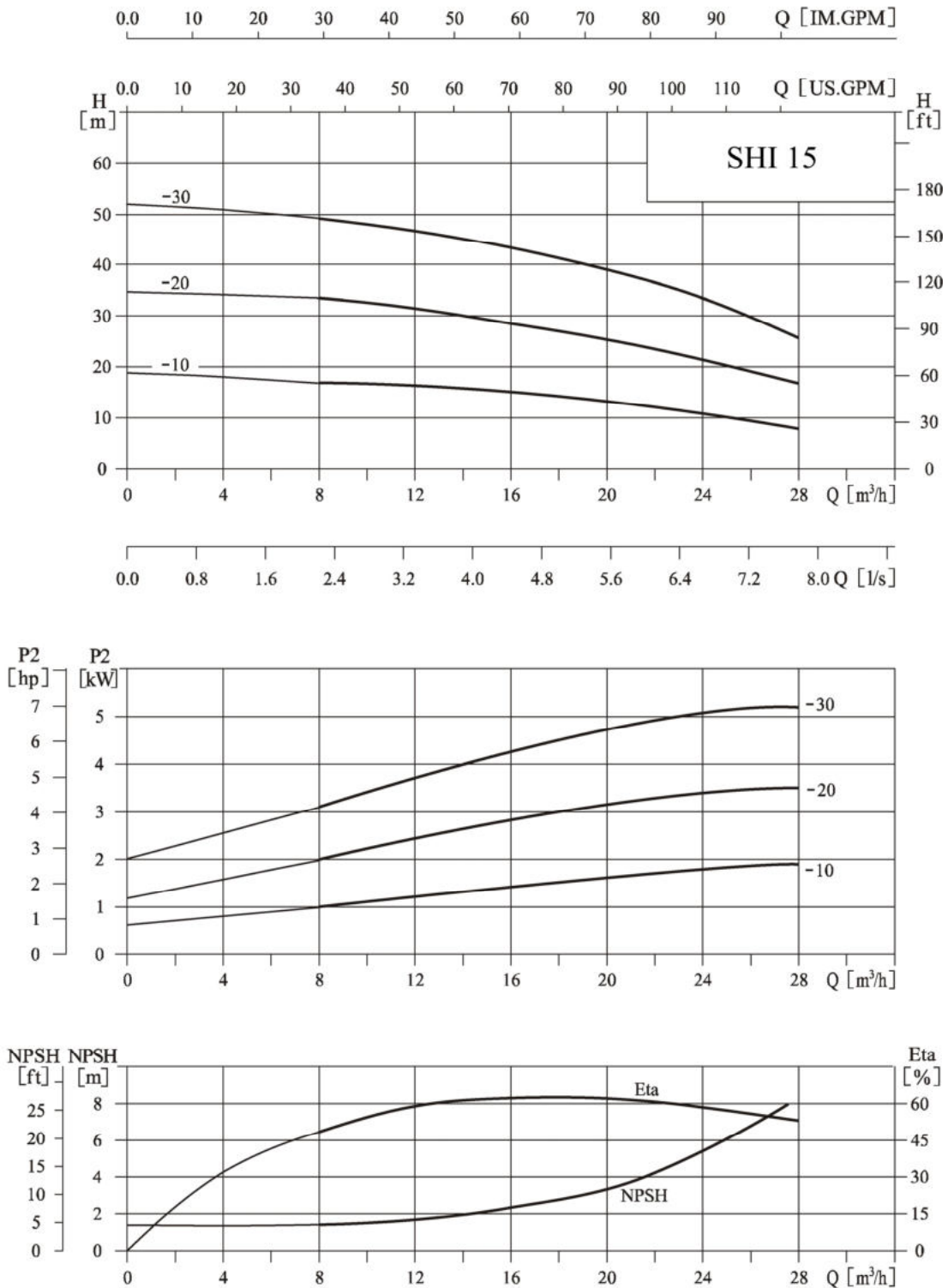

Αποδόσεις / Performance table

Τύπος Type	Ισχύς (KW)	Q (m ³ /h)	0,5	8	12	16	18	20	22	24	28
SHI 15-10	2,2	H (m)	19	17	16	15	14	13	12	11	8
SHI 15-20	4		34	33	31	29	28	26	23	21	17
SHI 15-30	5,5		51	49	47	44	42	39	37	34	25

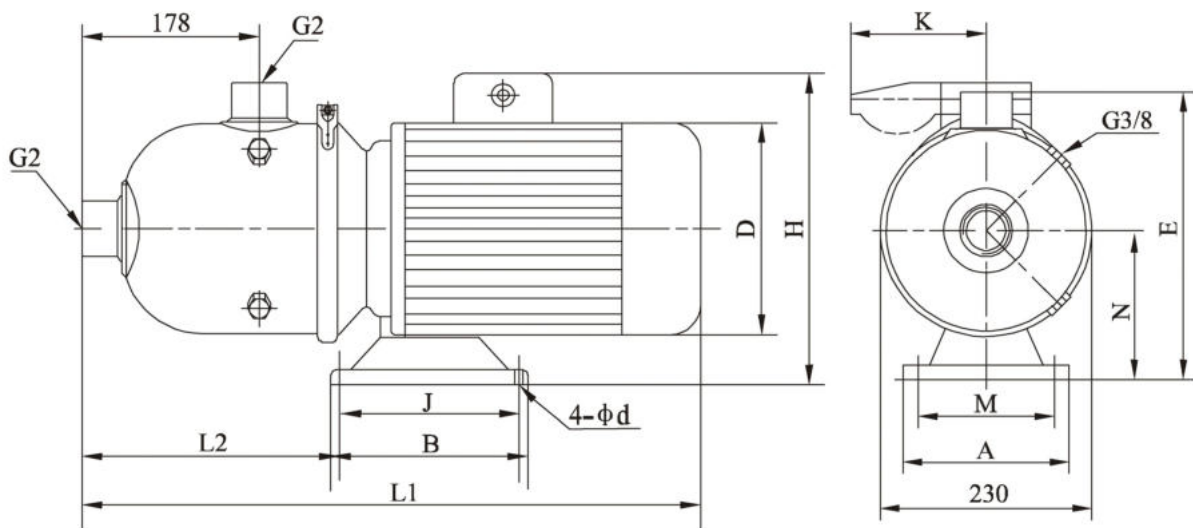

Διαστάσεις και Βάρη / Dimension and Weight

Κινητήρας Motor	Τύπος Type	Μήκος/Length (mm)											Βάρος Weight (kg)	
		L1	L2	H	E	B	D	J	A	M	N	d		K
Three Phase/ Single phase	SHI 15-10	580	280	230/270	264	160	180	138	130	108	118	9	/100	25
	SHI 15-20	650	360	270/-	270	170	220	140	230	190	120	12	-	43
	SHI 15-30	670	375	305/-	281	190	255	140	260	216	132	12	-	50

Αποδόσεις σε / Performance at 3500 r.p.m. 60 Hz

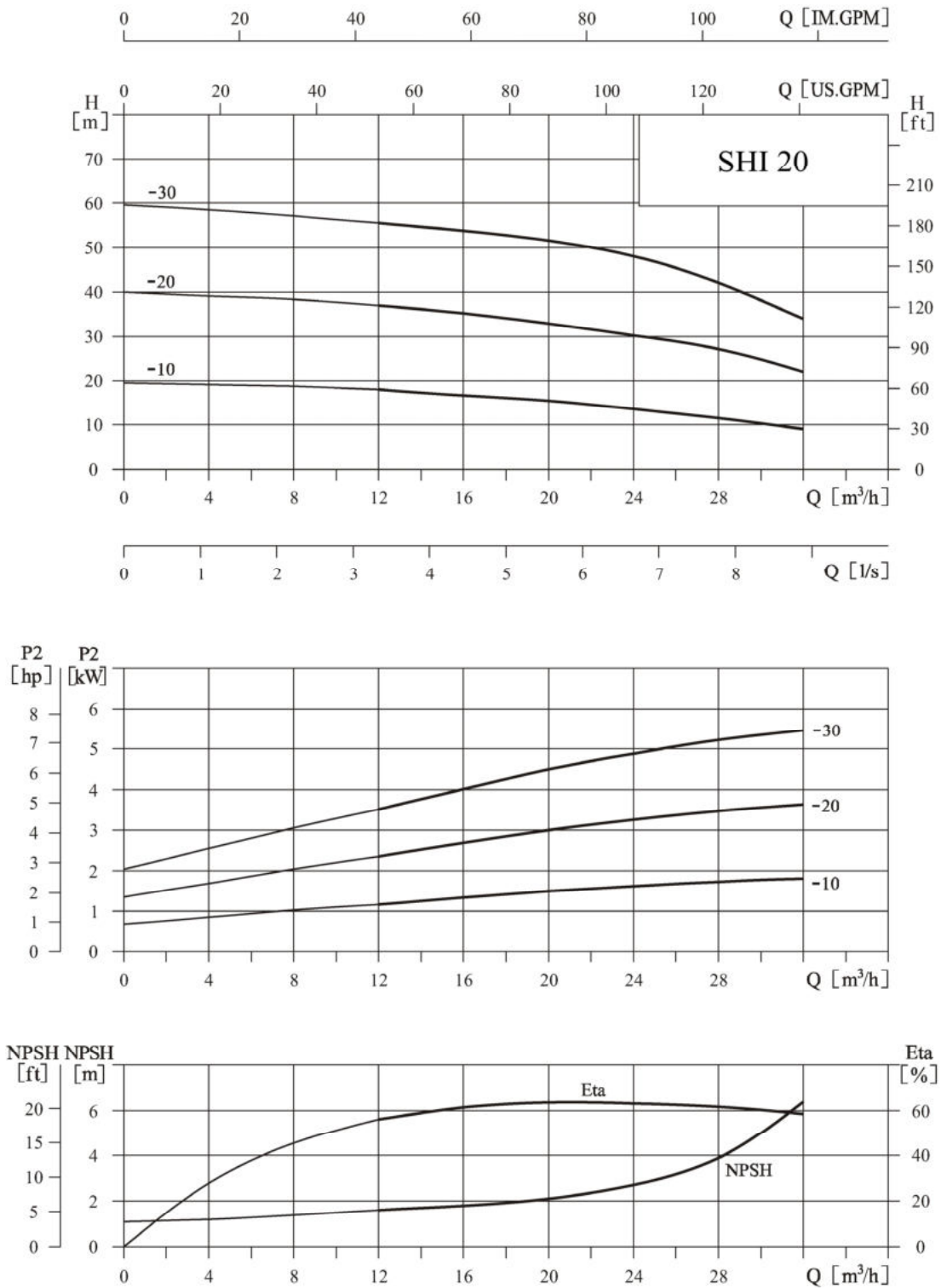

Αποδόσεις / Performance table

Τύπος Type	Ισχύς (KW)	Q (m ³ /h)	0,5	12	16	20	22	24	26	28	32
SHI 20-10	2,2	H (m)	20	18	17	16	15	14	13	12	9
SHI 20-20	4		40	37	35	33	32	30	29	28	22
SHI 20-30	5,5		59	55	54	52	50	48	46	42	34

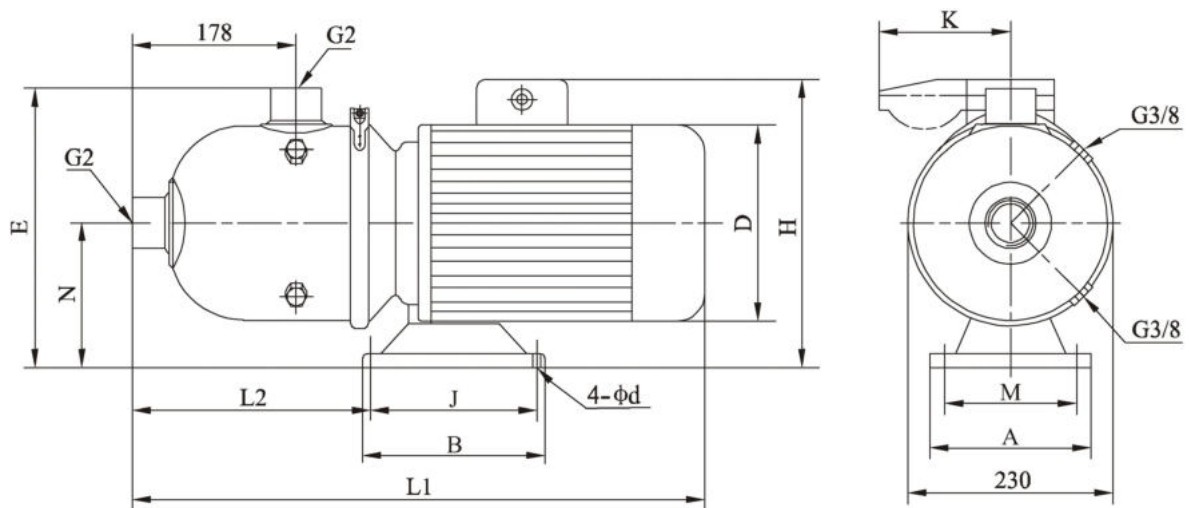

Διαστάσεις και Βάρη / Dimension and Weight

Κινητήρας Motor	Τύπος Type	Μήκος/Length (mm)											Βάρος Weight (kg)	
		L1	L2	H	D	E	N	A	M	B	J	d		K
Three Phase/ Single phase	SHI 20-10	580	280	240/270	180	268	118	130	108	160	138	9	/100	26
	SHI 20-20	650	360	270/-	220	270	120	230	190	170	140	12	-	43
	SHI 20-30	670	375	305/-	255	282	132	260	216	190	140	12	-	56

Αποδόσεις σε / Performance at 3500 r.p.m. 60 Hz

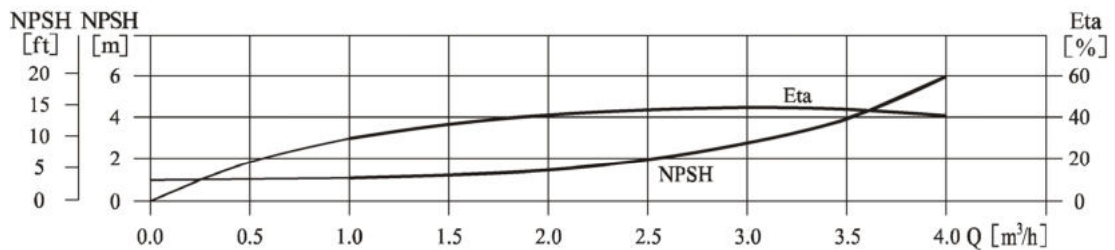
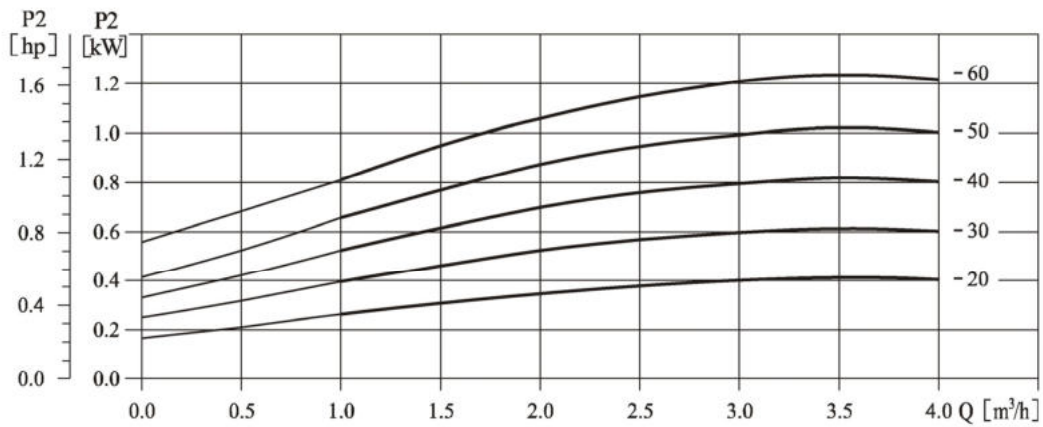
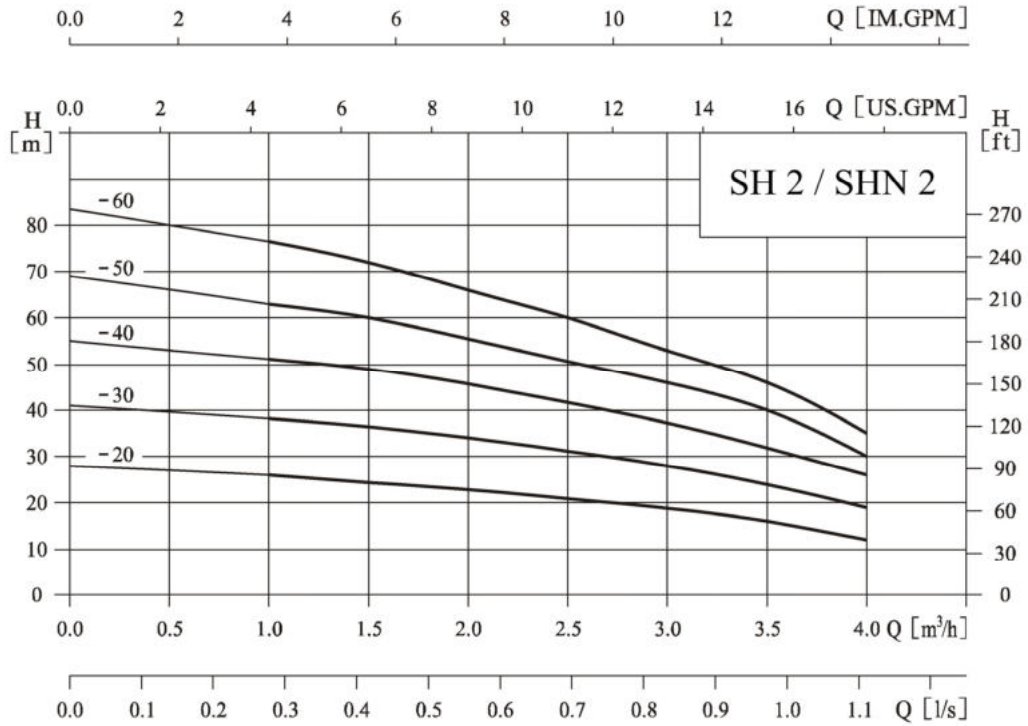

Αποδόσεις / Performance table

Τύπος Type	Ισχύς (KW)	Q (m ³ /h)	0,5	1	1,5	2	2,5	3	3,5	4
SH/SHN 2-20	0,55	H (m)	27	26	24	22	21	19	16	12
SH/SHN 2-30	0,75		40	38	36	34	31	28	24	19
SH/SHN 2-40	1,1		53	51	49	46	41	37	32	26
SH/SHN 2-50	1,1		66	63	60	56	51	46	40	30
SH/SHN 2-60	1,5		80	76	72	66	60	53	46	35

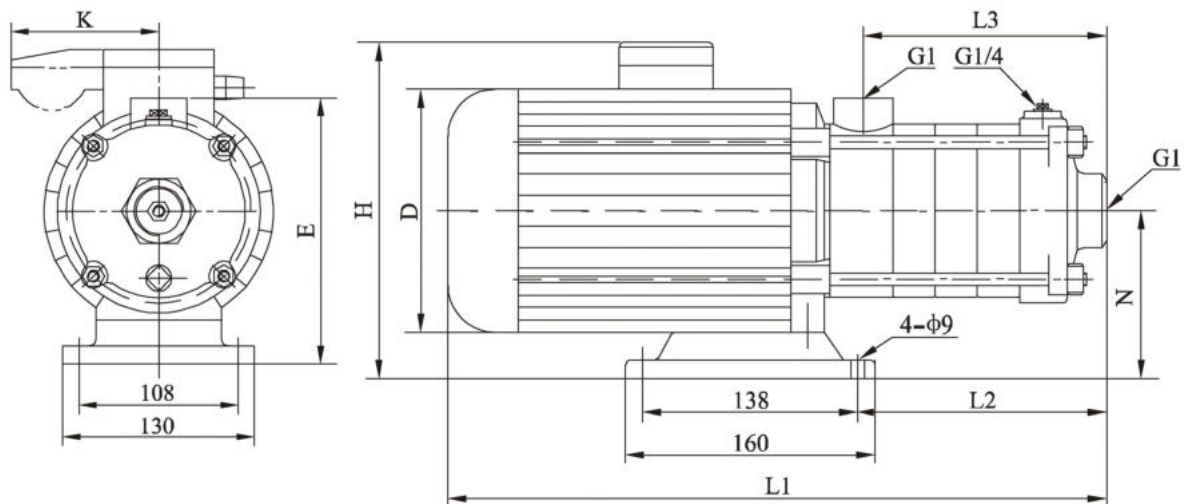

Διαστάσεις και Βάρη / Dimension and Weight

Κινητήρας Motor	Τύπος Type	Μήκος/Length (mm)								Βάρος Weight (kg)
		L1	L2	L3	E	H	N	D	K	
Three Phase/ Single phase	SH/SHN 2-20	305	87	84	182	230/230	110	145	/96	15
	SH/SHN 2-30	370	105	102	182	230/245	110	170	/100	17
	SH/SHN 2-40	388	123	120	182	230/245	110	170	/100	17
	SH/SHN 2-50	406	141	138	182	230/245	110	170	/100	17
	SH/SHN 2-60	465	159	156	190	240/260	118	170	/100	20

Αποδόσεις σε / Performance at 3500 r.p.m. 60 Hz

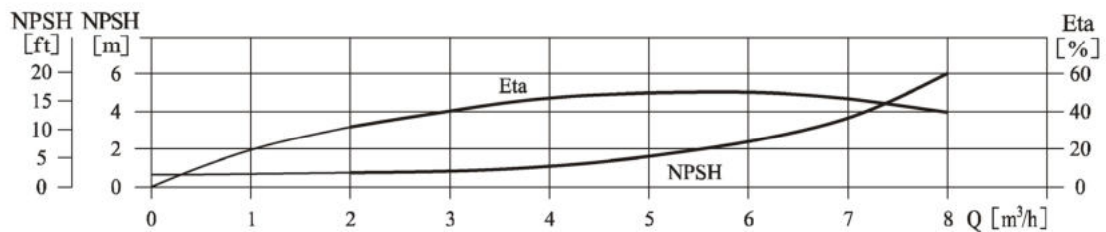
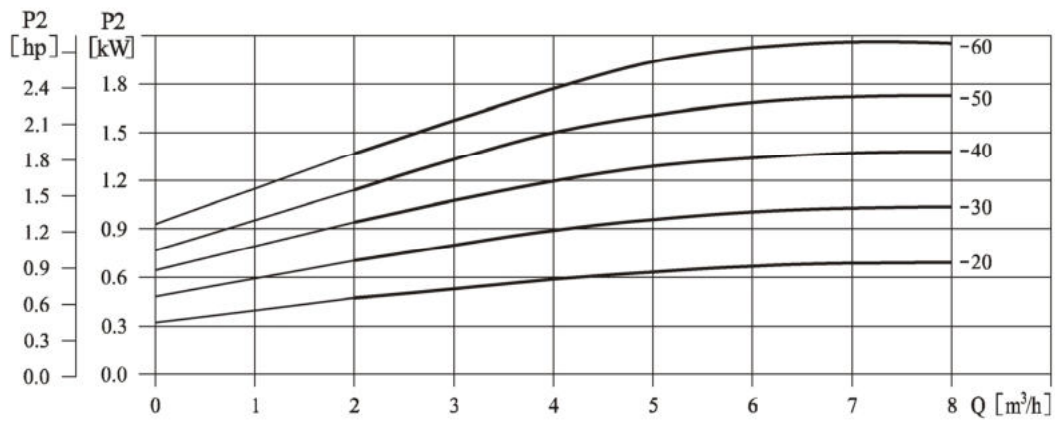
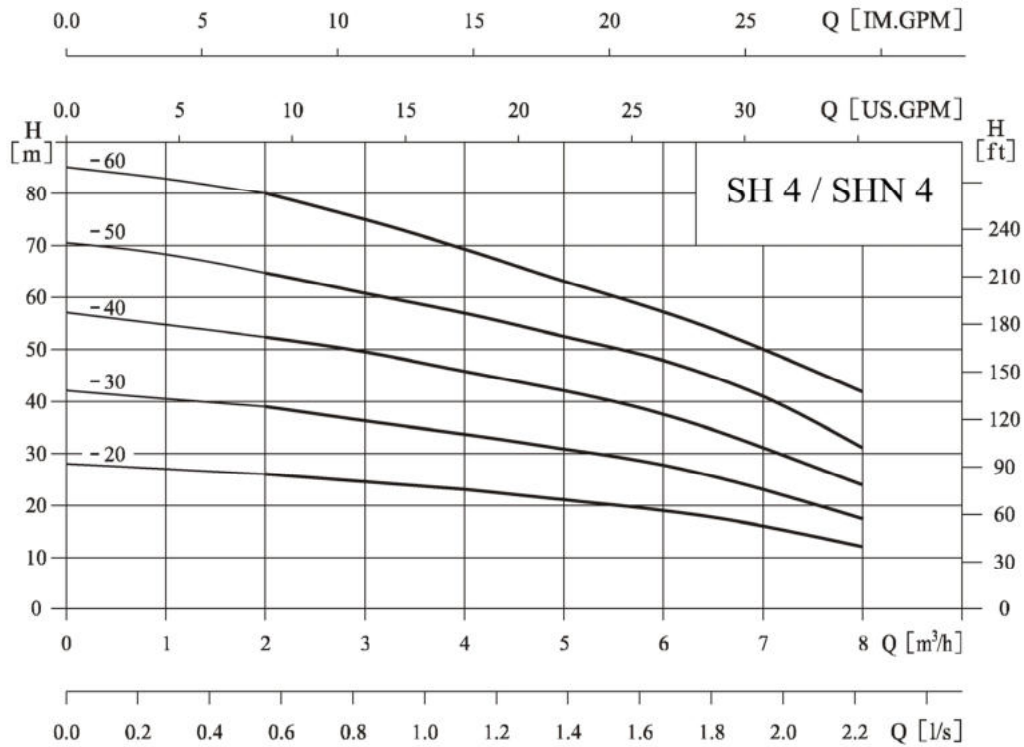

Αποδόσεις / Performance table

Τύπος Type	Ισχύς (KW)	Q (m ³ /h)	0,5	2	3	4	5	6	7	8
SH/SHN 4-20	0,75	H (m)	27	26	25	22	21	19	16	12
SH/SHN 4-30	1,1		41	39	36	33	31	28	23	18
SH/SHN 4-40	1,5		57	53	49	44	42	38	31	24
SH/SHN 4-50	2,2		70	65	61	57	52	48	41	32
SH/SHN 4-60	2,2		84	80	75	69	63	58	50	42

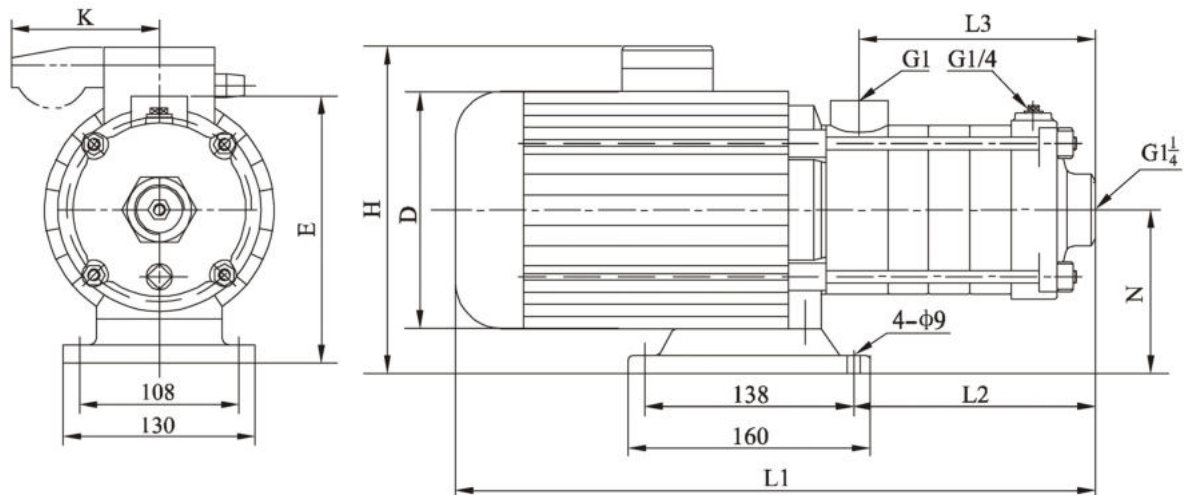

Διαστάσεις και Βάρη / Dimension and Weight

Κινητήρας Motor	Τύπος Type	Μήκος/Length (mm)								Βάρος Weight (kg)
		L1	L2	L3	E	H	N	D	K	
Three Phase/ Single phase	SH/SHN 4-20	359	105	102	182	230/245	110	170	/100	15
	SH/SHN 4-30	395	132	129	182	230/245	110	170	/100	17
	SH/SHN 4-40	465	159	156	190	240/260	118	170	/100	20
	SH/SHN 4-50	492	186	183	190	240/260	118	180	/100	25
	SH/SHN 4-60	519	213	210	190	240/260	118	180	/100	25

Αποδόσεις σε / Performance at 3500 r.p.m. 60 Hz

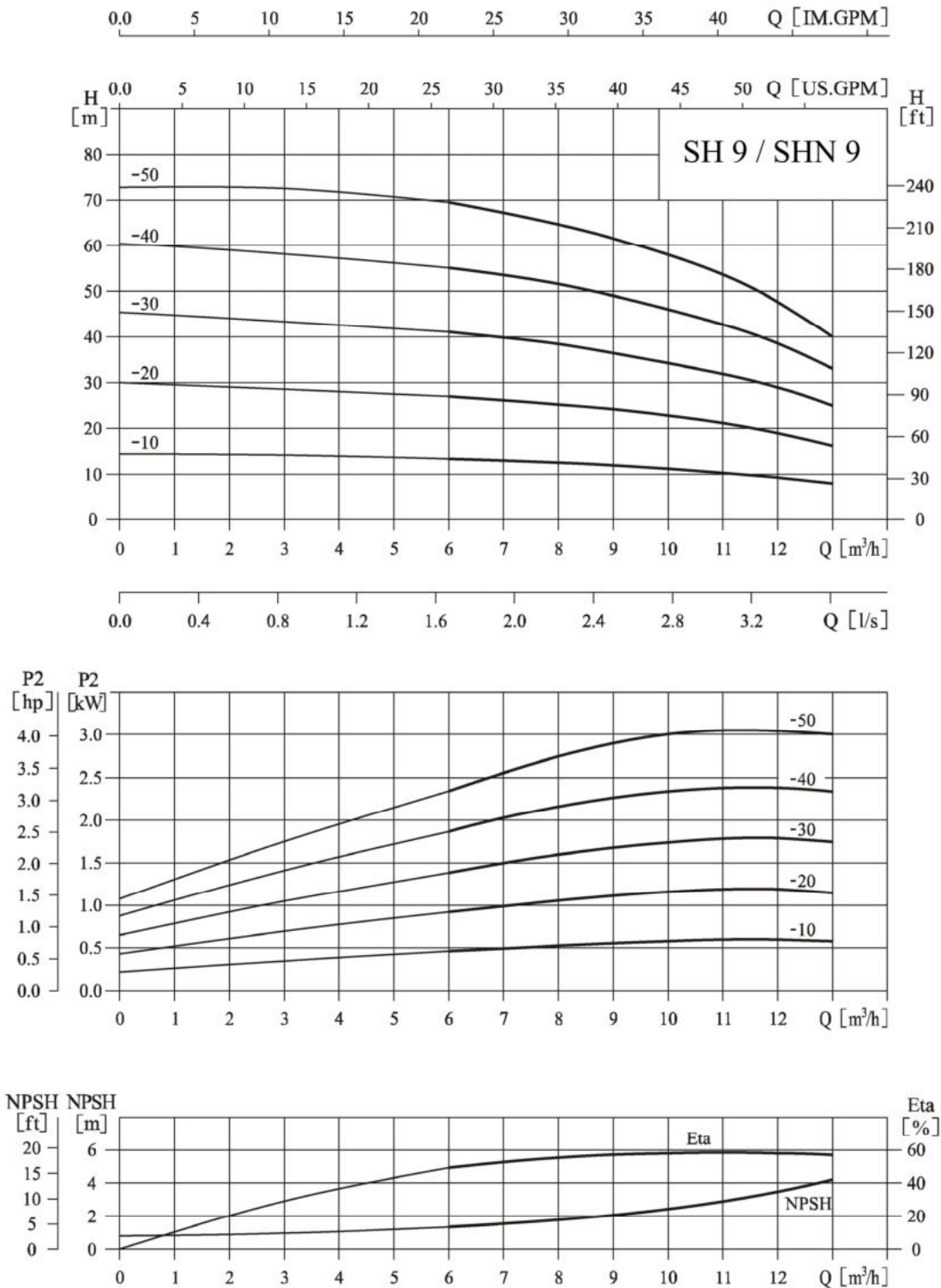

Αποδόσεις / Performance table

Τύπος Type	Ισχύς (KW)	Q (m ³ /h)	0,5	6	8	9	10	11	12	13
SH/SHN 9-10	0,75	H (m)	14	14	12	11,5	11	10	9	8
SH/SHN 9-20	1,5		30	27	25	24	23	21	19	16
SH/SHN 9-30	2,2		44	41	39	37	35	32	29	25
SH/SHN 9-40	3		60	55	52	50	47	43	39	33
SH/SHN 9-50	3		73	69	65	62	58	53	48	40

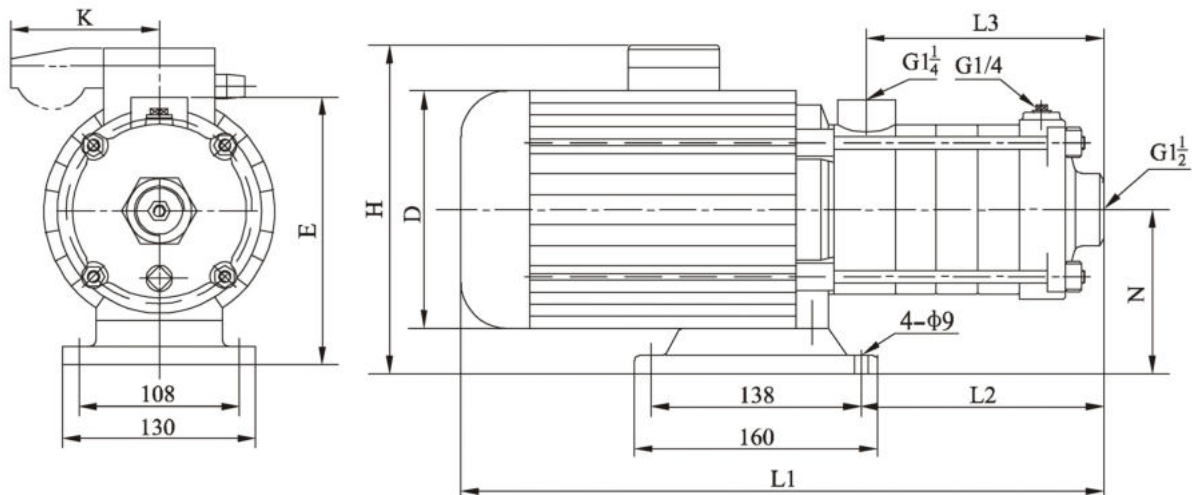

Διαστάσεις και Βάρη / Dimension and Weight

Κινητήρας Motor	Τύπος Type	Μήκος/Length (mm)								Βάρος Weight (kg)
		L1	L2	L3	E	H	N	D	K	
Three Phase/ Single phase	SH/SHN 9-10	395	128	108	227	230/265	117	170	/100	22
	SH/SHN 9-20	430	128	108	228	240/270	118	170	/100	25
	SH/SHN 9-30	460	158	138	228	240/270	118	170	/100	27
	SH/SHN 9-40	550	188	168	238	270/-	128	195	-	32
	SH/SHN 9-50	580	218	198	238	270/-	128	195	-	32

Αποδόσεις σε / Performance at 3500 r.p.m. 60 Hz

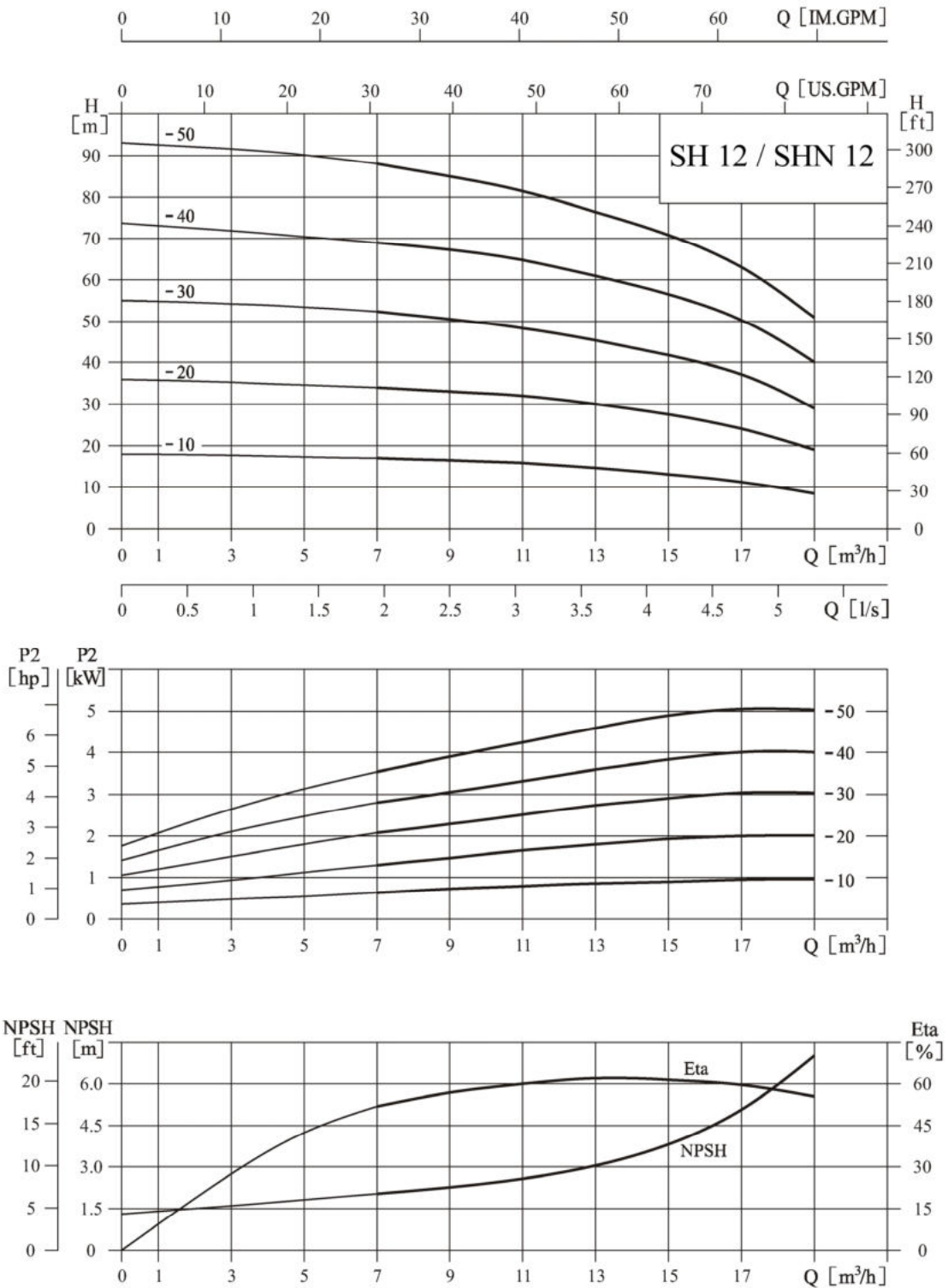

Αποδόσεις / Performance table

Τύπος Type	Ισχύς (KW)	Q (m ³ /h)	0,5	7	9	11	12	13	15	17	19
SH/SHN 12-10	1,1	H (m)	18	17	16,5	16	15	14,5	13	11,5	9
SH/SHN 12-20	2,2		36	34	33	32	31	30	27	25	19
SH/SHN 12-30	3		55	53	51	48	47	45	42	38	29
SH/SHN 12-40	4		74	69	67	65	63	61	56	50	40
SH/SHN 12-50	5,5		93	88	85	82	79	77	71	63	51

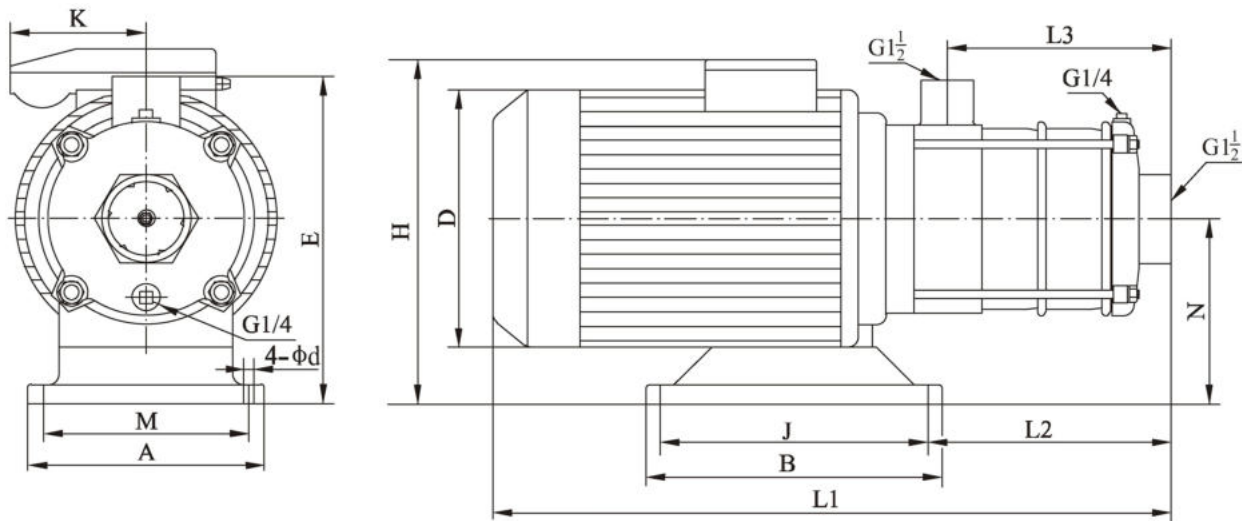

Διαστάσεις και Βάρη / Dimension and Weight

Κινητήρας Motor	Τύπος Type	Μήκος/Length (mm)													Βάρος Weight (kg)
		L1	L2	L3	H	D	E	N	A	M	B	J	d	K	
Three Phase/ Single phase	SH/SHN 12-10	395	126	108	230/265	180	227	117	130	108	160	138	9	/100	22
	SH/SHN 12-20	430	126	108	240/270	180	228	118	130	108	160	138	9	/100	25
	SH/SHN 12-30	510	156	138	270/-	195	240	130	130	108	160	138	9	-	32
	SH/SHN 12-40	565	285	168	270/-	220	230	120	230	190	170	140	12	-	44
	SH/SHN 12-50	620	325	198	305/-	255	242	132	260	216	190	140	12	-	58

Αποδόσεις σε / Performance at 3500 r.p.m. 60 Hz

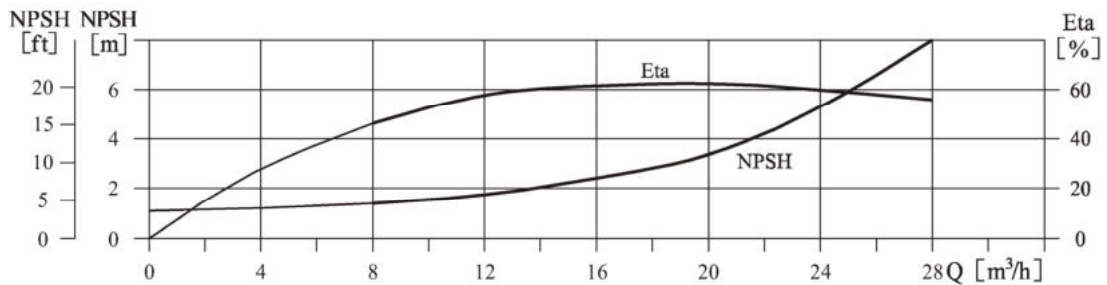
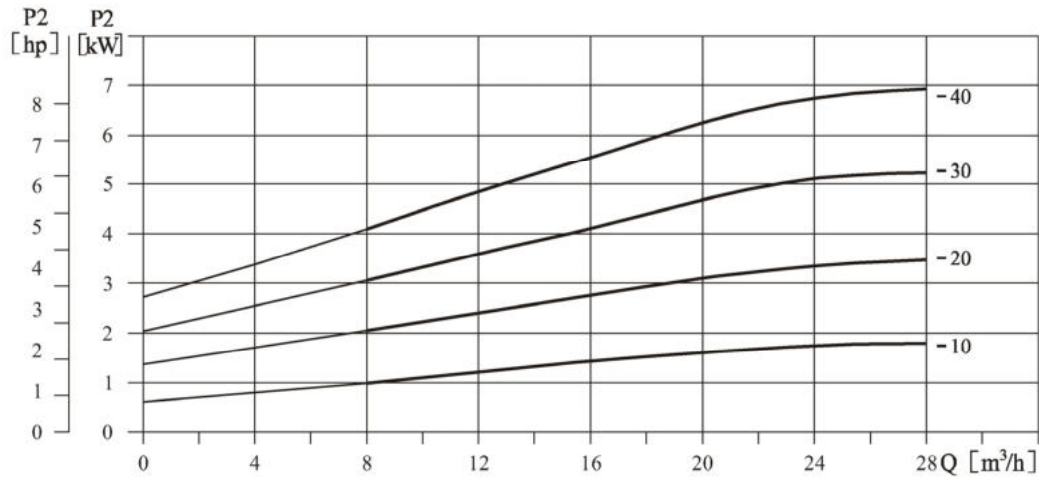
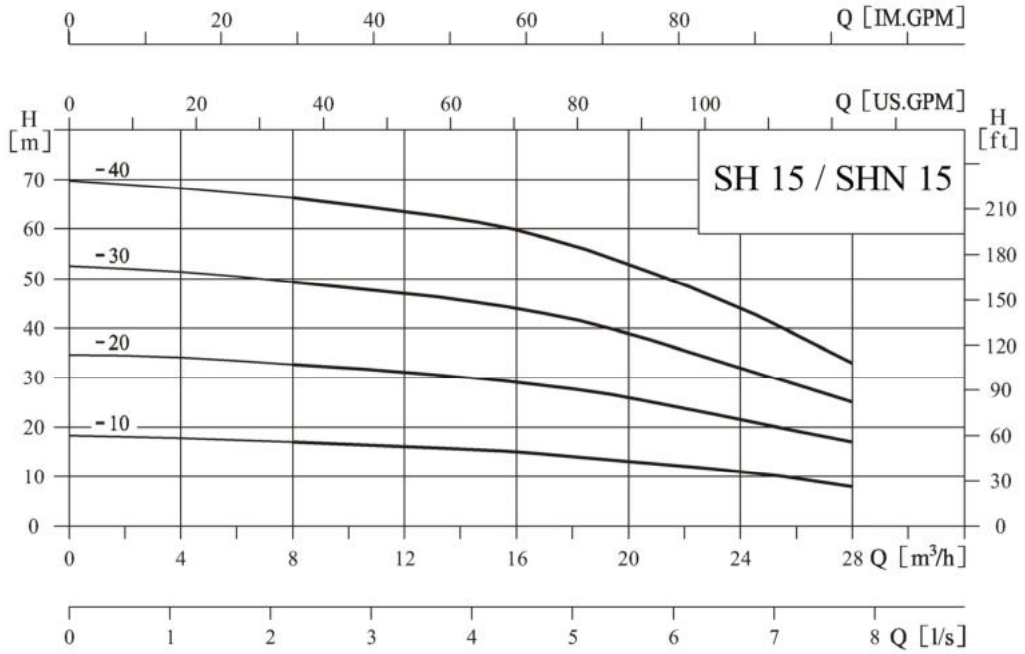

Αποδόσεις / Performance table

Τύπος Type	Ισχύς (KW)	Q (m ³ /h)	0,5	8	12	16	18	20	22	24	28
SH/SHN 15-10	2,2	H (m)	19	17	16	15	14	13	12	11	8
SH/SHN 15-20	4		35	33	31	29	28	26	23	21	17
SH/SHN 15-30	5,5		52	49	47	44	42	39	37	32	25
SH/SHN 15-40	7,5		70	66	63	60	57	53	49	44	33

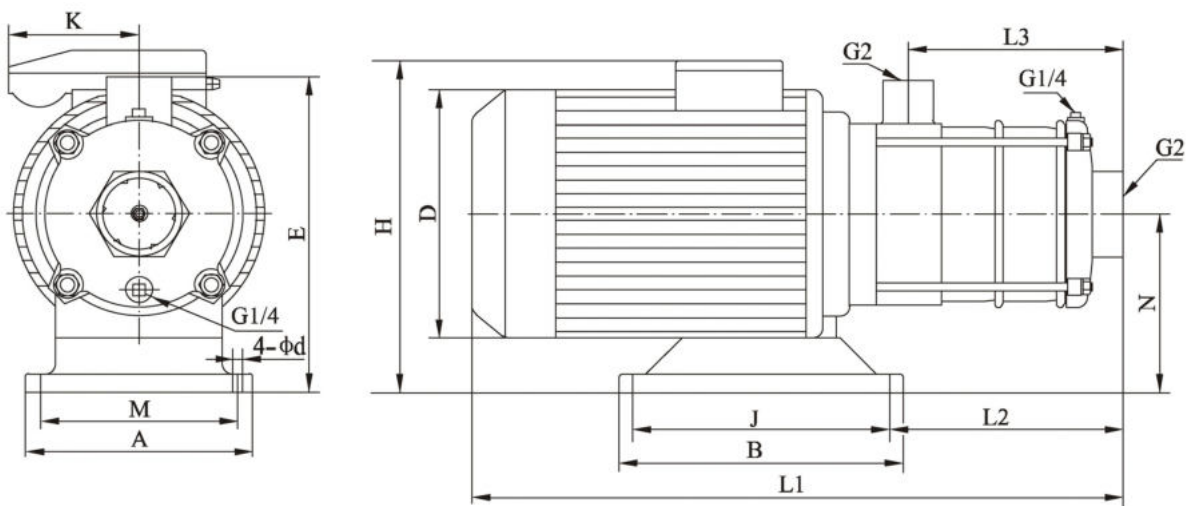

Διαστάσεις και Βάρη / Dimension and Weight

Κινητήρας Motor	Τύπος Type	Μήκος/Length (mm)													Βάρος Weight (kg)
		L1	L2	L3	H	D	E	N	A	M	B	J	d	K	
Three Phase/ Single phase	SH/SHN 15-10	455	151	126	240/270	180	228	118	131	108	161	138	9	/100	26
	SH/SHN 15-20	531	249	126	270/-	220	230	120	230	190	170	140	12	-	43
	SH/SHN 15-30	600	310	171	305/-	255	242	132	260	216	190	140	12	-	56
	SH/SHN 15-40	645	355	216	305/-	255	242	132	260	216	190	140	12	-	63

Αποδόσεις σε / Performance at 3500 r.p.m. 60 Hz

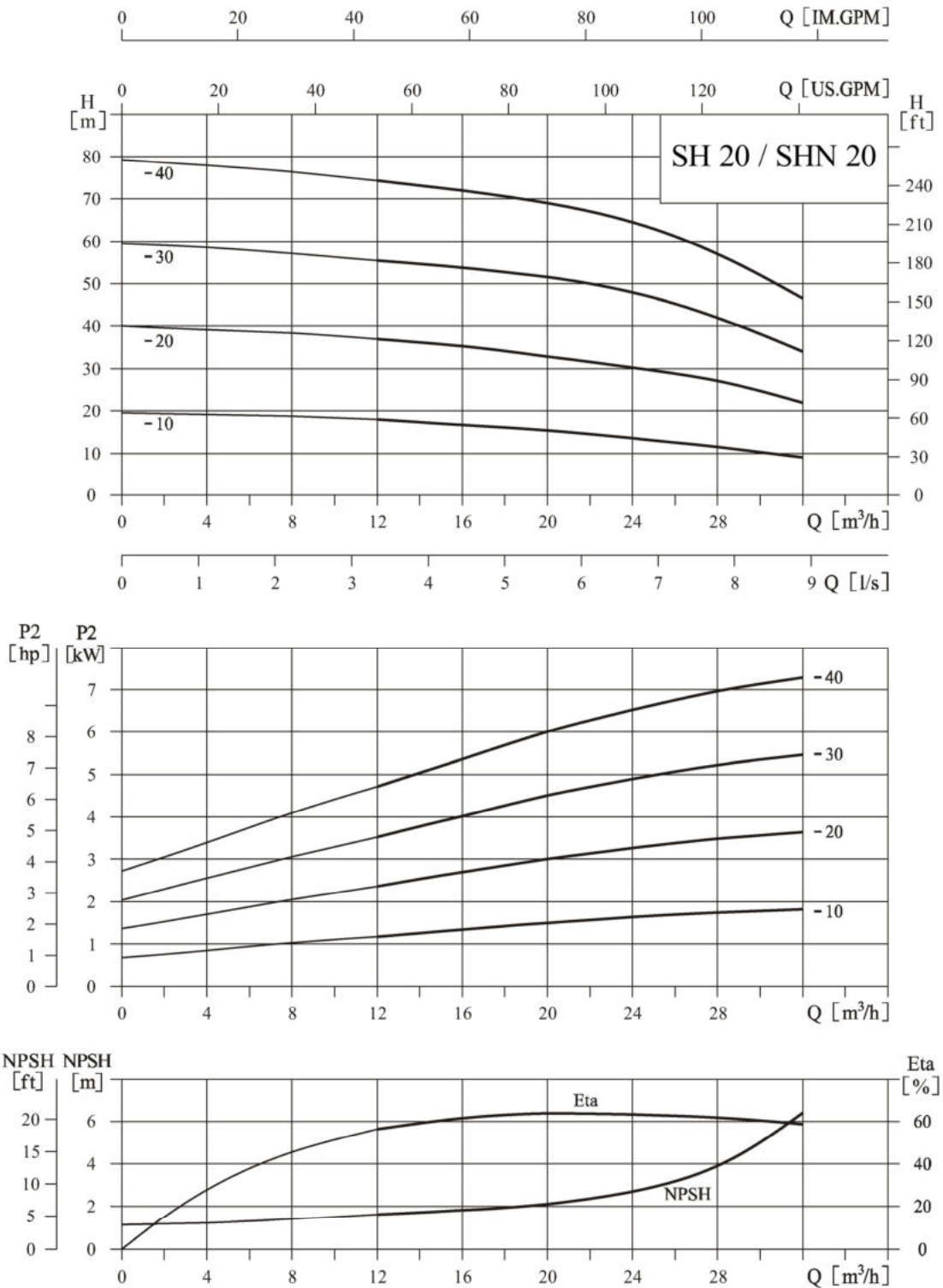

Αποδόσεις / Performance table

Τύπος Type	Ισχύς (KW)	Q (m ³ /h)	0,5	12	16	20	22	24	26	28	32
SH/SHN 20-10	2,2	H (m)	20	18	17	15	15	14	13	12	9
SH/SHN 20-20	4		40	37	35	33	32	30	29	28	22
SH/SHN 20-30	5,5		59	55	54	52	50	48	46	42	34
SH/SHN 20-40	7,5		79	74	72	69	67	65	62	57	47

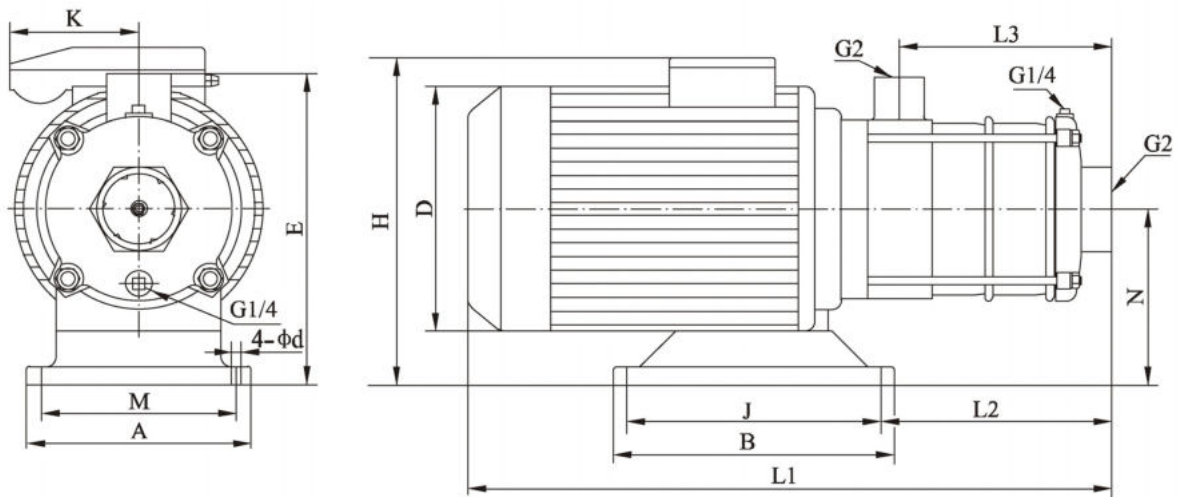

Διαστάσεις και Βάρη / Dimension and Weight

Κινητήρας Motor	Τύπος Type	Μήκος/Length (mm)													Βάρος Weight (kg)
		L1	L2	L3	H	D	E	N	A	M	B	J	d	K	
Three Phase/ Single phase	SH/SHN 20-10	455	151	126	240/270	180	228	118	130	108	160	138	9	/100	26
	SH/SHN 20-20	531	249	126	270/-	220	230	120	230	190	170	140	12	-	43
	SH/SHN 20-30	600	310	171	305/-	255	242	132	260	216	190	140	12	-	56
	SH/SHN 20-40	645	355	216	305/-	255	242	132	260	216	190	140	12	-	63

Submersible & Axial Pumps Industry
FLINOS BROS - K. MARINAKIS S.A.

7th klm. Argos 212 00 ARGOS - GREECE
Tel. +30 27510 91498, 91490 - Fax. 91009

E-mail: anavalos@otenet.gr, web site: www.anavalos.gr



Βιομηχανία Αντλιών
ΑΦΟΙ ΦΛΙΝΟΥ - Κ. ΜΑΡΙΝΑΚΗΣ Α.Β.Ε.Ε.

7ο χλμ. Άργους - Κορίνθου 21 200 Άργους -
Τηλ. 27510 91498, 91490 - Fax. 91009