

### Features

- Non self priming pump
- Dual mechanical seal
- Thermal protection
- Motor protection IP44
- Insulation class F
- Maximum suction depth 8m



### Απόδοση

- Capacity up to 6 m<sup>3</sup>/h.
- Manometric Head up to 55 m
- Revolution speed 2900 r.p.m

### Εφαρμογές

- Domestic or building use.
- Water transfer from wells or tanks
- Garden irrigation.
- Combined with pressure controller
- Combined with pressure tank.

### Υλικά

- Motor casing made of aluminum.
- Shaft made of stainless steel AISI 304
- Impeller made of thermoplastic PPO
- Pump body made of stainless steel AISI 304
- Pump suction base made of cast iron.

### Multi

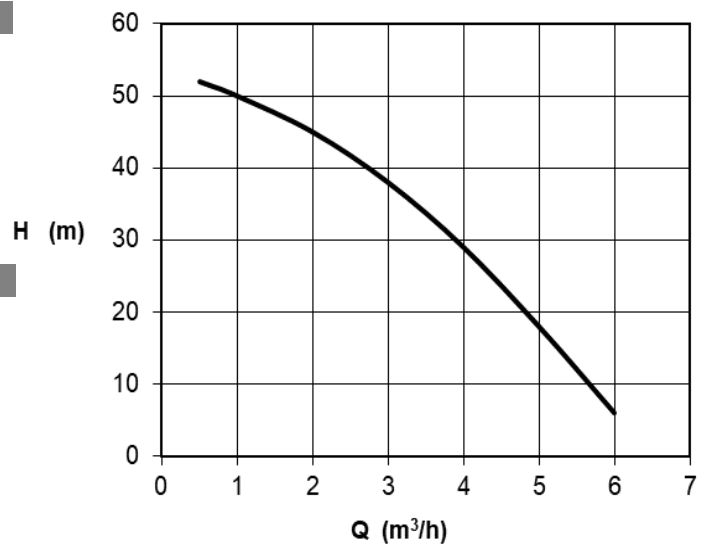

TYPE	VOLT	MOTOR kW	m <sup>3</sup> /h	0,5	1	2	3	4	5	6
			l/min	8,33	16,66	33,32	50	66,64	75	100
Multi 3/5	220V	1,1		52	50	45	38	29	18	6

Dimensions

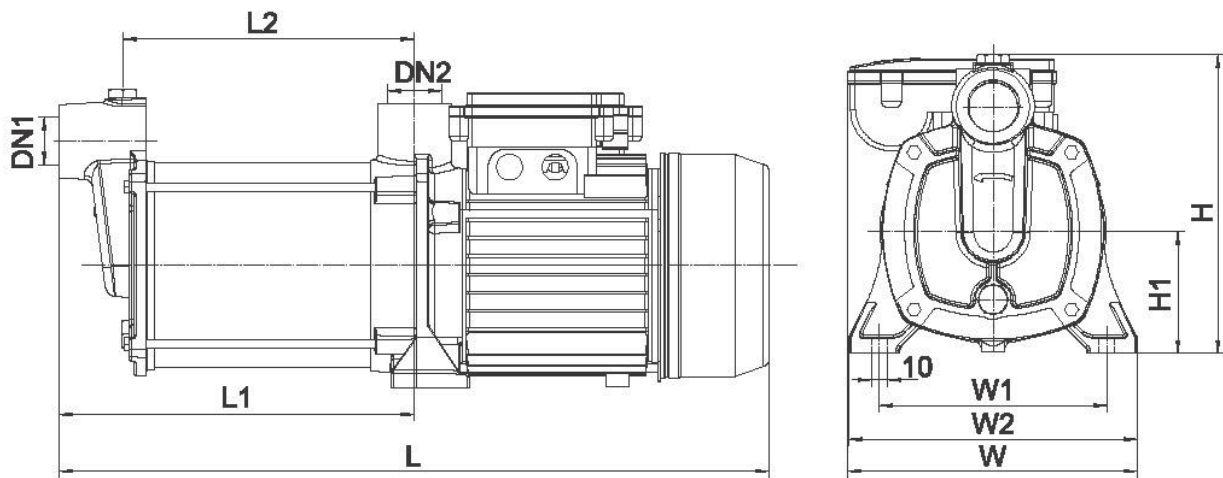

TYPE	L (mm)	W (mm)	H (mm)	L1 (mm)	L2 (mm)	W1 (mm)	W2 (mm)	H1 (mm)	DN1	DN2	Weight
Multi 3/5	438	179	185	220	180	176	125	75	1"	1"	14kg