

Self Priming Pumps (JET)

JET

WORKING PRINCIPLE

Self priming is achieved using a Venturi pipe, house in pump body. Only a part of the total capacity produced by the impeller is delivered to the discharge. The remaining capacity is re-circulated through the Venturi pipe, which is connected to the suction chamber, generating the necessary vacuum to self-prime the pump. When first starting the pump fill the pump with water. The water circulates in the pump body transferring any air form the delivery chamber to the discharge. At the same time the vacuum generated causes water to rise in the suction piping, thus self priming the pump. These pumps are suitable for cases where there is presence of large amounts of entrained air in the fluid being pumped.

All pumps are designed with particular attention to hydraulic efficiency and choice of materials. The result is quality, quiet high performance pumps.

PUMP INSTALLATION AND APPLICATIONS

The series Jet is suitable for pumping clean water of temperature up to 40 °C and for fluids that are not chemically aggressive to the pump components. Very easy to use and specially designed for domestic applications like home booster systems, water distribution from tank to tank, garden irrigation etc. These pumps should always be installed in covered area, protected against the weather. It is always advised to use a foot valve or a non return valve on the suction opening.

CHARACTERISTICS

- Cast iron or stainless steel pump casing with inlet and outlet of female thread for easy use.
- Threaded side opening for installing pressure gauge and pressure switch.
- Shaft made of stainless steel.
- Dual ceramic mechanical seal made of carbon SiC.
- Radial impellers made of bronze or technopolymere.
- TEFC motors of low noise, air cooled, continuous duty, high efficiency, insulation class F, protection IP44.
- Built-in thermal protection.

Features

- Self priming pump (JET)
- Dual mechanical seal
- Thermal protection
- Motor protection IP44
- Insulation class F
- Maximum suction depth 7m

Performance

- Capacity up to 3,5 m³/h.
- Manometric Head up to 50 m.
- Maximum diameter of incoming particles 3 mm.
- Revolution speed 2900 r.p.m.

Applications

- Domestic or building use.
- Water transfer from wells or tanks.
- Garden irrigation.
- Combined with inverter
- Combined with pressure tank

Materials

- Motor casing made of aluminum.
- Shaft made of stainless steel AISI 304.
- Impeller made of technopolymere.
- Pump casing made of stainl. steel AISI 304



Jet 100X

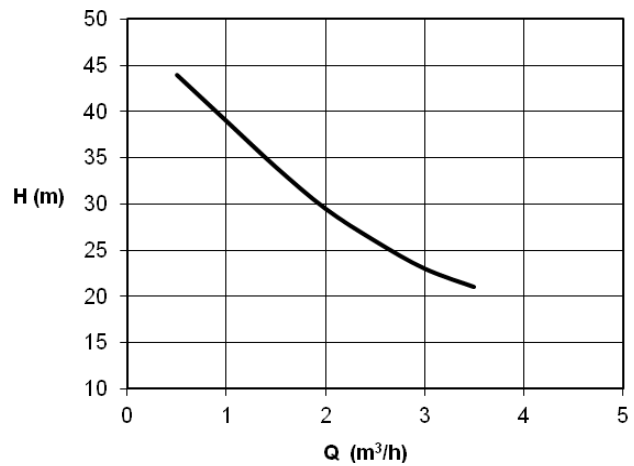

TYPE	VOLT	MOTOR KW	m ³ /h	0,5	1	1,5	2	2,5	3	3,5
			l/min	8,3	16,7	25	33,3	41,7	50	58,3
Jet 100X	220V	0,75	H (m)	44	39	34	29,5	26	23	21

Dimensions

JET 100X

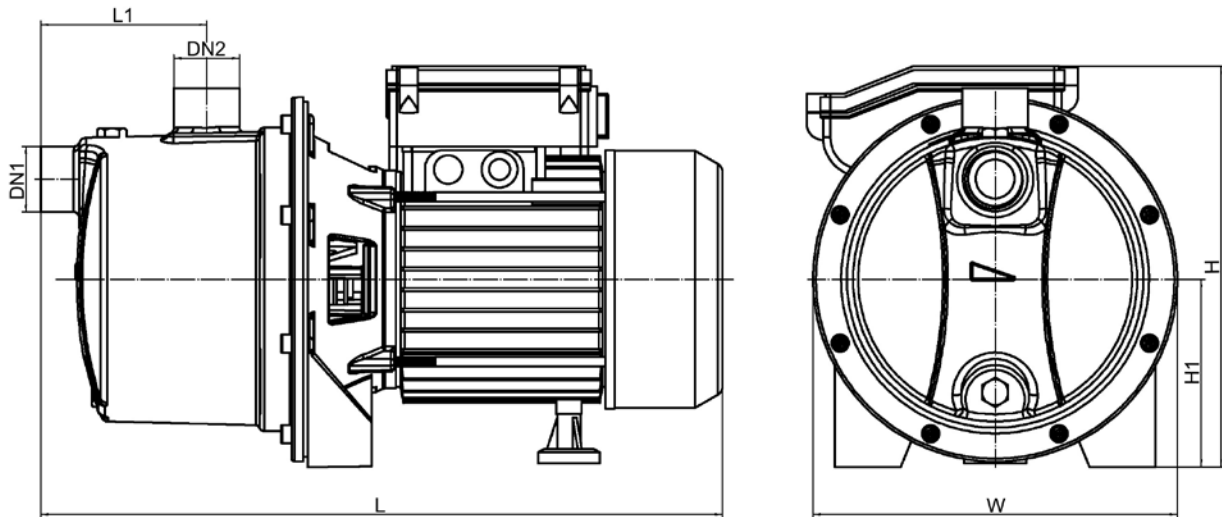

TYPE	L (mm)	H (mm)	W (mm)	L1 (mm)	H1 (mm)	DN1	DN2	Weight
Jet 100X	379	200	171	91	103	1"	1"	9.8kg