

Features

- Single stage centrifugal pump
- Dual mechanical seal
- Thermal protection
- Motor protection IP54
- Insulation class F
- Maximum suction depth 7m

Performance

- Capacity up to 60 m³/h.
- Manometric Head up to 23 m.
- Maximum diameter of incoming particles 3 mm
- Revolution speed 2900 r.p.m.

Applications

- Domestic or building use.
- Water transfer from wells or tanks.
- Garden irrigation.
- Combined with inverter.
- Combined with pressure tank.

Materials

- Motor casing made of aluminum.
- Shaft made of stainless steel AISI 304.
- Impeller made of bronze.
- Pump casing made of cast iron.



CDS

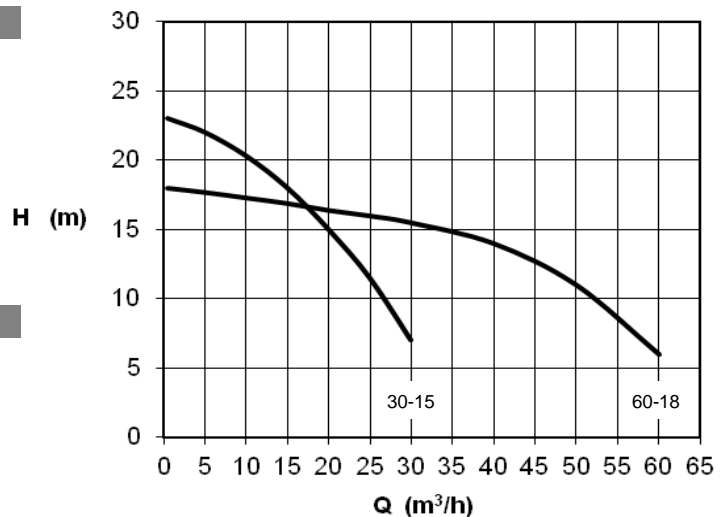

TYPE	VOLT	MOTOR KW	m ³ /h	0,5	5	10	15	20	25	30	40	50	60
			l/min	8,3	83,3	166,6	250	333,2	416,5	500	666,4	833,0	1000
CDS 30-15	220V	1,1	H (m)	23	22	20,3	18	15	11,5	7			
CDS 60-18	400V	2,2		18	17,7	17,3	16,9	16,4	16	15,5	14	11	6

Dimensions

CDS

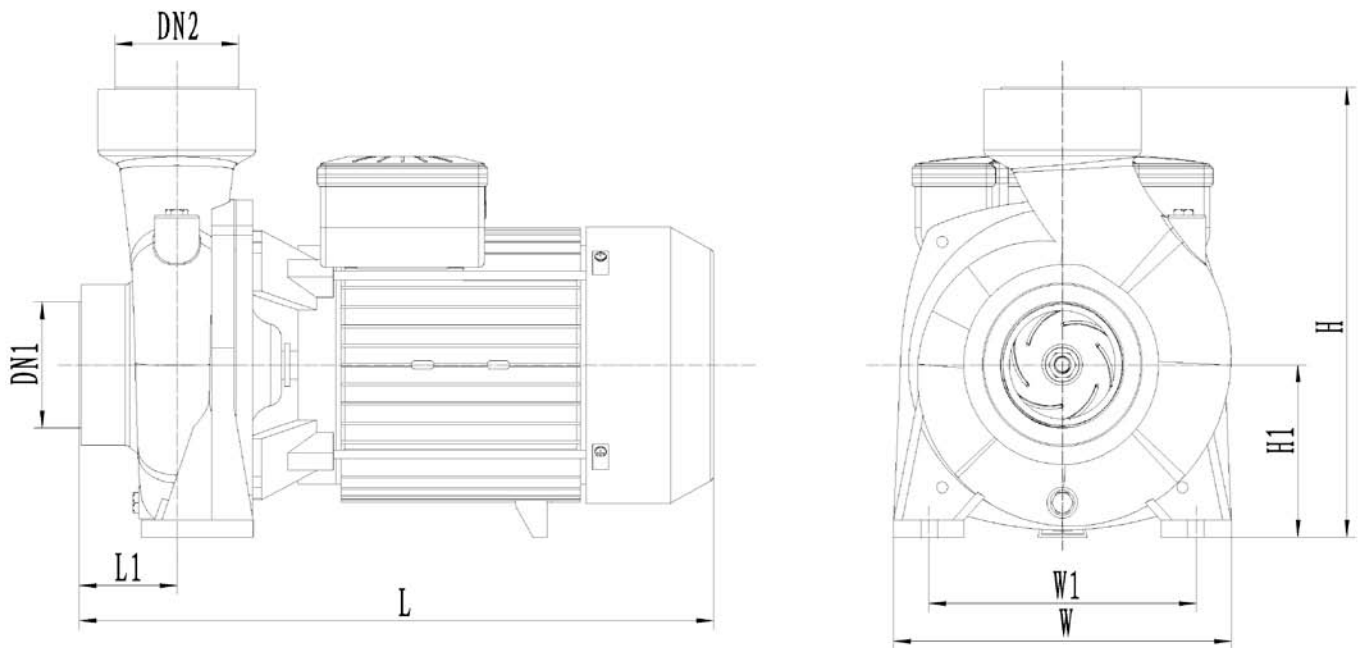

TYPE	L (mm)	W (mm)	H (mm)	L1 (mm)	H1 (mm)	W1 (mm)	DN1	DN2	Weight
CDS 30-15	335	190	245	62	97	160	2'	2''	34kg
CDS 60-18	451	240	313	69	120	190	3'	3''	46kg