

Features

- Stainless steel drainage pump
- Internal motor cooling for longer life lasting
- Pumping for high head (3 bar)
- Dual mechanical seal
- Thermal protection
- Float switch
- Motor protection IP68
- Insulation class F
- Maximum immersion depth 5m

Performance

- Capacity up to 6 m³/h
- Manometric Head up to 33 m
- Maximum content in sand 100 gr/m³

Applications

- Small tanks
- Garage
- Basement

Materials

- Motor casing made of stainl. steel AISI 304
- Shaft made of stainless steel AISI 304
- Impeller made of stainless steel AISI 304
- Pump casing made of stainl. steel AISI 304



ASTRA XT

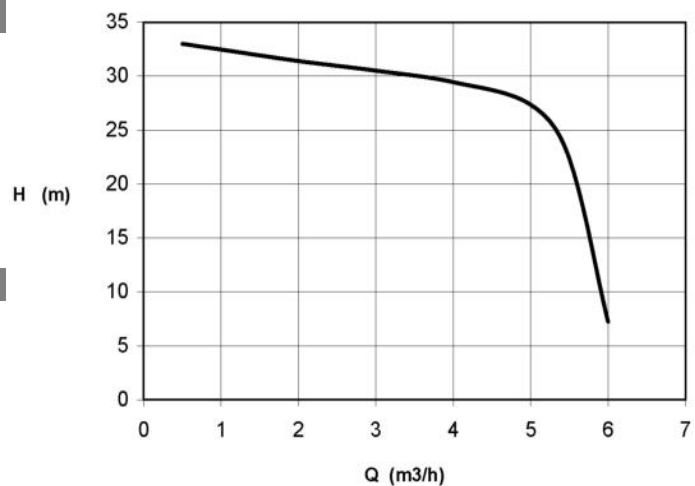

TYPE	VOLT	POWER kW	m ³ /h	0,5	1	2	3	4	5
			l/min	8,3	16,7	33,3	50	66,7	83,3
Astra XT 750	220V	0,75	H (m)	33	32,4	31,4	30,5	29,5	27,5

Dimensions

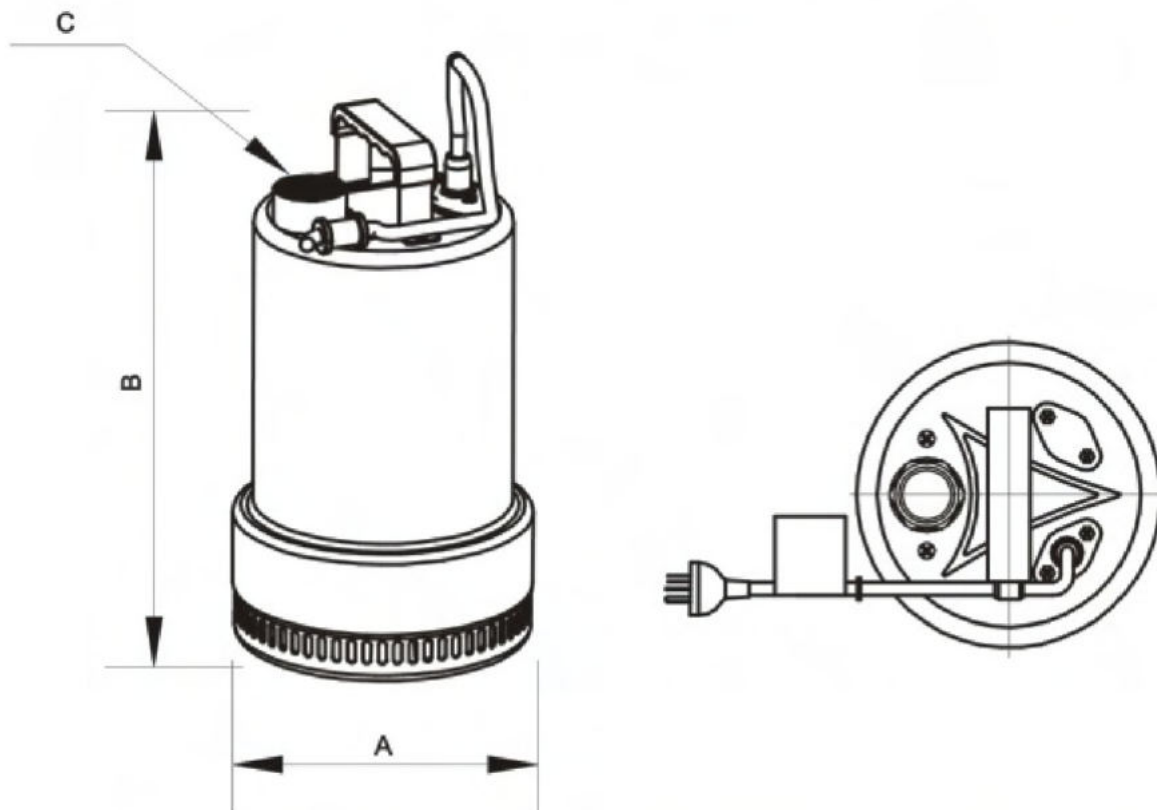

TYPE	A (mm)	B (mm)	C Discharge	Weight
Astra XT 750	185	340	1 1/4"	13Kg