

General

- Automatic sewage pump lift station
- Impeller with cutters
- Dual mechanical seal
- Thermal protection
- Automatic operation with air-pressure sensor
- Motor protection IP44
- Insulation class F

Features

- Silent operation
- Easy installation with toilet, basin, bathroom
- Impeller with cutting system
- System against fiber and blockage
- Integrated non return valve
- Start / stop: 90mm / 40mm from ground

Advantages

- Max head 8.5m
- Easy installation with many accessories included in package
- Top or side outlet port selection
- Available to connect with washing machine
- Easy replacement of pump-motor set on site

Performance

- Capacity up to 5 m³/h
- Manometric Head up to 8,5 m
- Maximum fluid temperature +50 °C

Applications

- Sewage and waste water
- WC in basement

Materials

- Tank made of noryl
- Stainless steel blades



ARGOLIFT-82C

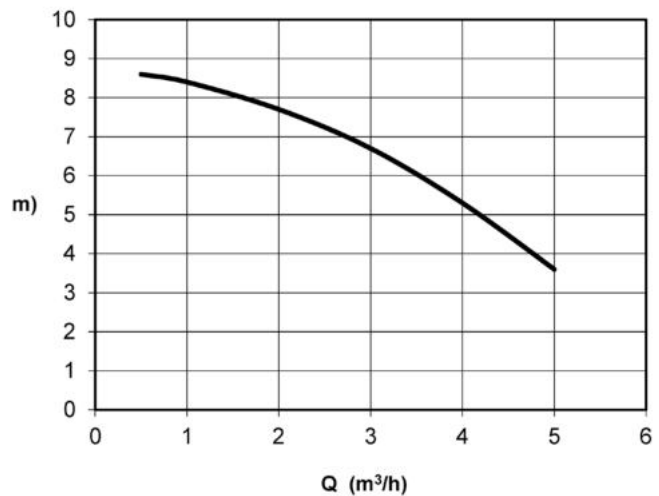

TYPE	VOLT	POWER W	Max. Diam. Of Particles	m ³ /h	0,5	1	2	3	4	5
				l/min	8	17	33	50	67	83
Argolift-82C	220V	600	cutters	H (m)	8,6	8,4	7,7	6,7	5,3	3,6

Dimension

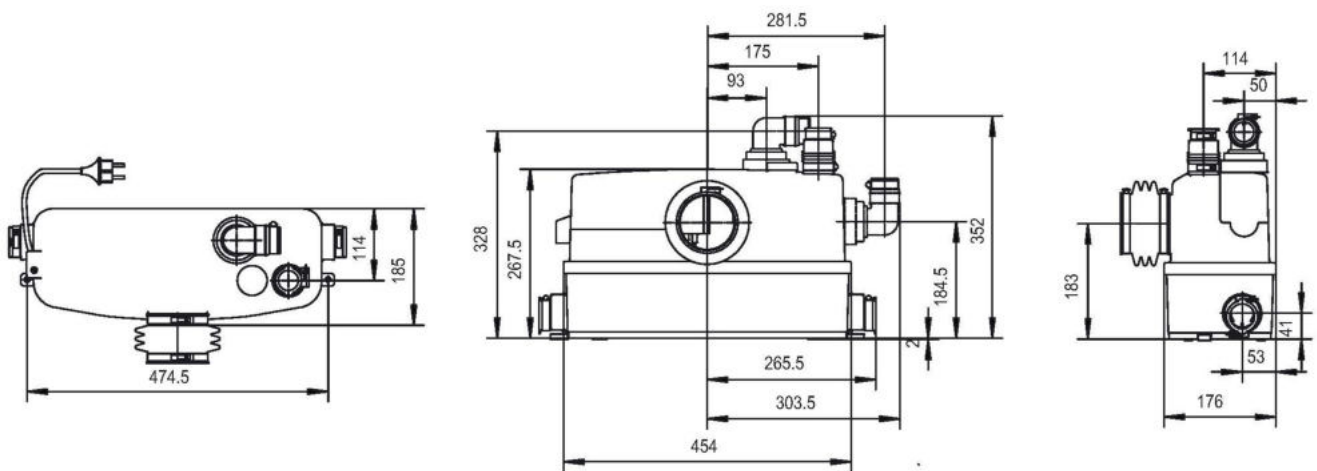

TYPE	L (mm)	W (mm)	H (mm)	D Discharge	Weight
Argolift-82C	454	176	352	1''	6kg