

Features

- Stainless steel for light sewage water
- Internal motor cooling for longer life lasting
- Dual mechanical seal
- Thermal protection
- Float switch
- Motor protection IP68
- Insulation class F
- Maximum immersion depth 5m

Performance

- Capacity up to 21 m³/h
- Manometric Head up to 13,5 m
- Max. diameter of incoming particles 38 mm

Applications

- Small tanks
- Garage
- Basement
- Domestic use for sewage and waste water
- Industrial use
- Sea water pumping

Materials

- Motor casing made of stainl. steel AISI 304
- Shaft made of stainless steel AISI 304
- Impeller made of stainless steel AISI 304
- Pump casing made of stainl. steel AISI 304



ARGO XS

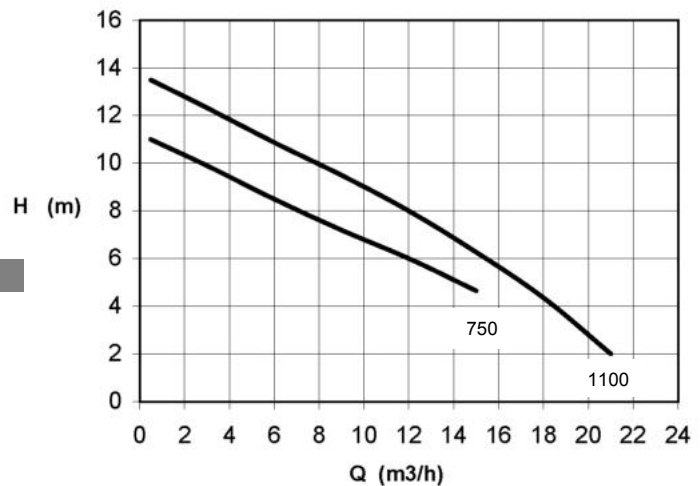

TYPE	VOLT	MOTOR KW	PARTICLES MAX DIAMETER	Capacity (Q) [m ³ /h]								
				0,5	3	6	9	12	15	18	21	
Argo XS 750	220V	0,75	38mm	l/min	8,3	50	100	150	200	250	300	350
				H (m)	11	9,9	8,5	7,2	6	4,8		
Argo XS 1100	220V	1,1	38mm	H (m)	13,5	12,3	10,9	9,5	8	6,3	4,5	2

Dimensions

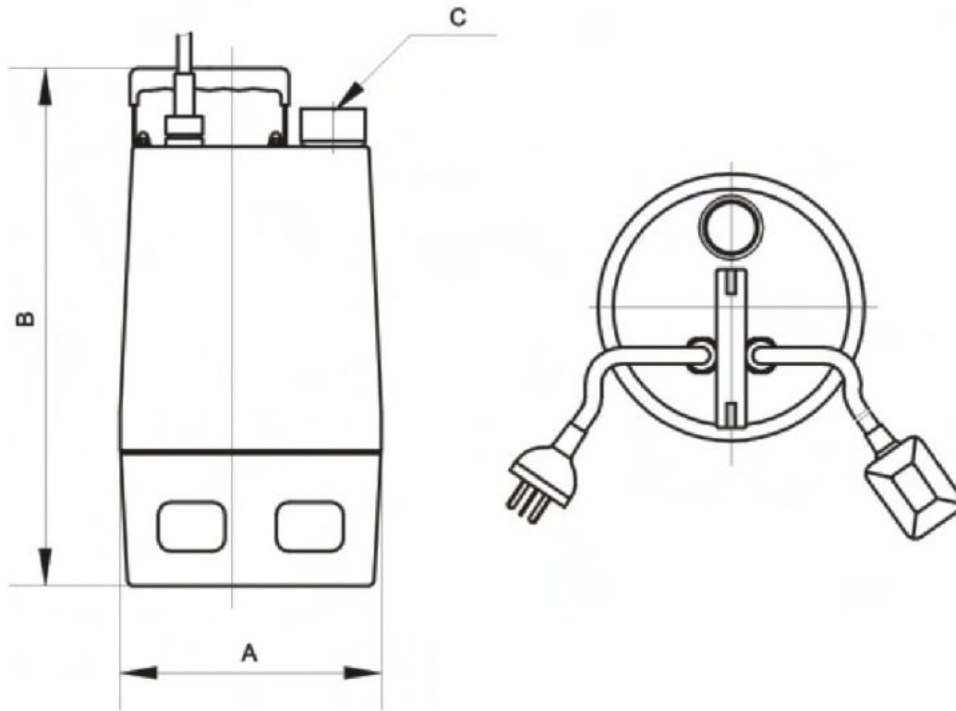

TYPE	A (mm)	B (mm)	C Discharge	Weight
Argo XS 750	220	430	1''1/2	17kg
Argo XS 1100	220	430	1''1/2	18kg