

Features

- Light sewage water pump
- Dual mechanical seal
- Thermal protection
- Motor protection IP68
- Insulation class F
- Float switch
- Maximum immersion depth 5m

Performance

- Capacity up to 36 m³/h
- Manometric Head up to 15 m
- Max. diameter of incoming particles 50 mm

Applications

- Small tanks
- Garage
- Basement
- Domestic use of sewage water

Materials

- Motor casing made of stainl. steel AISI 304
- Shaft made of stainless steel AISI 304
- Impeller made of cast iron
- Pump casing made of cast iron



ARGO GX

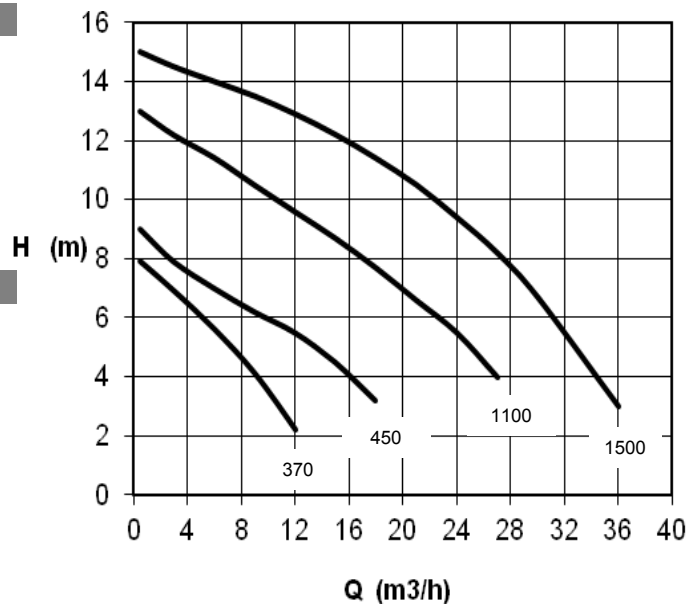

| TYPE | VOLT | MOTOR KW | PARTICLES MAX DIAMETER | m ³ /h l/min | H (m) | | | | | | | | | | | |
|--------------|------|----------|------------------------|----------------------------|-------|------|-------|------|------|------|------|------|-----|-----|----|--|
| | | | | | 0,5 | 3 | 6 | 9 | 12 | 15 | 18 | 21 | 24 | 27 | 36 | |
| Argo GX 370 | 220V | 0,25 | 28mm | 50 | 7,9 | 6,9 | 5,6 | 4,1 | 2,2 | | | | | | | |
| Argo GX 450 | 220V | 0,37 | 38mm | 100 | 9 | 7,9 | 7 | 6,2 | 5,5 | 4,5 | 3,2 | | | | | |
| Argo GX 1100 | 220V | 1,1 | 50mm | 250 | 13 | 12,2 | 11,43 | 10,5 | 9,6 | 8,7 | 7,7 | 6,6 | 5,5 | 4 | | |
| Argo GX 1500 | 220V | 1,5 | 50mm | 350 | 15 | 14,5 | 14 | 13,5 | 12,9 | 12,2 | 11,4 | 10,5 | 9,4 | 8,2 | 3 | |

Dimensions

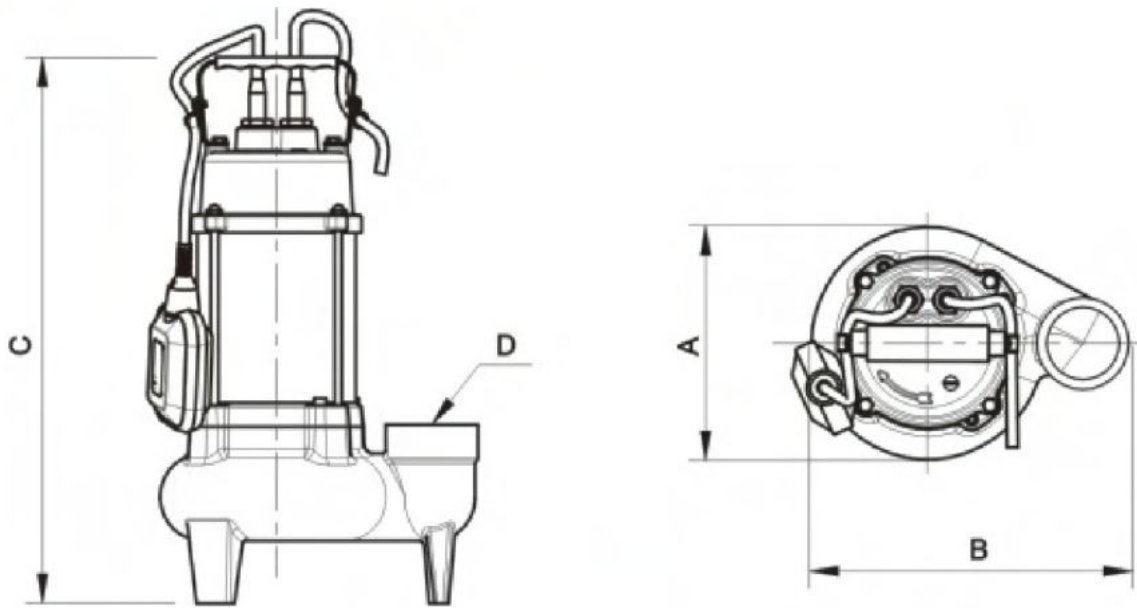

| TYPE | A (mm) | B (mm) | C (mm) | D Discharge | Weight |
|--------------|--------|--------|--------|-------------|--------|
| Argo GX 370 | 130 | 170 | 340 | 1'' 1/4 | 10kg |
| Argo GX 450 | 195 | 265 | 455 | 2'' | 18kg |
| Argo GX 1100 | 195 | 265 | 478 | 2'' | 23kg |
| Argo GX 1500 | 195 | 265 | 515 | 2'' | 26kg |